

Study on laser assisted milling of ferrous based consolidated material

著者	Furumoto Tatsuaki, Ueda Takashi, Osaka Teruyuki, Yassin Abdullah, Hosokawa Akira, Tanaka Ryutaro
journal or publication title	Journal of Mechanical Science and Technology
volume	24
number	1
page range	127-130
year	2010-02-01
URL	http://hdl.handle.net/2297/23905

doi: 10.1007/s12206-009-1158-x

Study on Laser Assisted Milling of Ferrous Based Consolidated Material†

Tatsuaki Furumoto¹, Takashi Ueda¹, Teruyuki Osaka²,
Abdullah Yassin², Akira Hosokawa¹ and Ryutaro Tanaka¹

¹*Institute of Science and Engineering, Kanazawa University, Kakuma-machi, Kanazawa, Ishikawa, 920-1192, Japan*

²*Graduate School of Natural Science and Technology, Kanazawa University,
Kakuma-machi, Kanazawa, Ishikawa, 920-1192, Japan*

(Manuscript Received May 2, 2009; Revised *****; Accepted *****)

Abstract

This study deals with the laser beam assisted milling to improve the machinability of a consolidated structure formed by layered manufacturing processes. The laser beam used is a continuous CO₂ laser with a maximum output power of 100 W. The metal powder for layered manufacturing is a ferrous-based mixture. In order to investigate the influence of laser conditions on the machinability, specific cutting force, tool wear and tool temperature of the flank face are measured. The results showed that the specific cutting force of the consolidated structure decreased by the effect of energy input on the structure surface. The progress of wear on the flank face assisted by the laser beam was 20% slower due to the softening of the consolidated structure and the melting of the powder which remained on the structure surface. The dimensional accuracy and surface finishing of the consolidated structure were influenced by the rise of the tool temperature on the flank face.

Keywords: Carbon dioxide laser beam, Cutting temperature, End milling, Ferrous based metal powder, Rapid prototyping, Specific cutting force, Tool wear, Two-color pyrometer

1. Introduction

Recently, a multifunction machine, in which a ferrous based powder bed is selectively heated and fused by a laser beam irradiation and the edge of consolidated structure obtained is cut with end mill, has been developed to produce an injection molding die [1]. In this device, a small ball end mill is generally used to gain a precision dimension and high quality surface. However, the surface of a consolidated structure is difficult to cut due to its hardness and the insufficient

melting of metal powder.

In this study, laser beam assisted milling is proposed for the improvement of the machinability of a consolidated structure formed by layered manufacturing processes. In order to investigate the influence of the laser conditions on the machinability of a consolidated structure, specific cutting force, tool wear and tool temperature of the flank face are measured experimentally.

2. Characteristics of work material

The procedure for consolidating work material is schematically illustrated in Fig. 1. This system is composed of a Yb: fiber laser and a consolidation unit of a metal powder. Since a recoating blade is attached

†This paper was presented at the ICMDT 2009, Jeju, Korea, June 2009. This paper was recommended for publication in revised form by Gest Editors Sung-Lime Ko, Keiichi Watanuki.

*Corresponding author. Tel.: +81 76 234 4723, Fax.: +81 76-234-4723.

E-mail address: furumoto@t.kanazawa-u.ac.jp

© KSME & Springer 2010.

Table 1 Specification of metal powder

Material	SCM, Cu, Ni
Shape	Irregular
Particle mean diameter	d 25 μm
Bulk density	ρ 4190 kg/m^3
Absorption ratio	A_r 25%
Thermal conductivity	K 0.14 $\text{W/(m}\cdot\text{K)}$

Table 2 Property of the consolidated structure

Hardness	HV 330
Bulk density	ρ 7680 kg/m^3
Thermal conductivity	K 8.0 $\text{W/(m}\cdot\text{K)}$
Melting point	M 1300 $^\circ\text{C}$

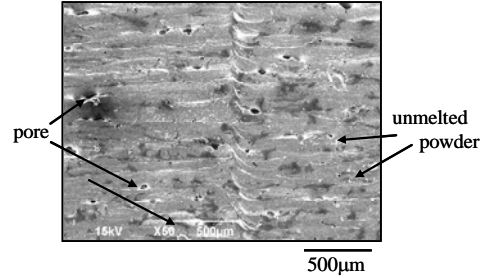
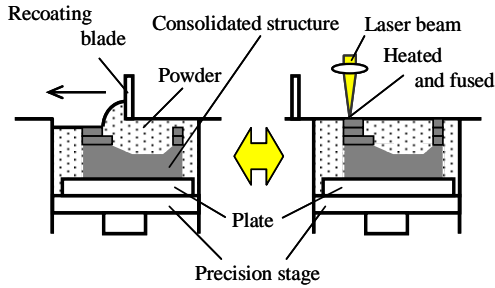

Fig.2 SEM image of the consolidated surface

in the consolidation unit, it is possible to deposit metal powder at a thickness of $t = 50 \mu\text{m}$. The laser beam is irradiated to the powdered surface through a galvanometer mirror at the focus spot, and scanned on it with programmed NC data. After forming a layer of consolidation, these processes are repeatedly performed as the scan direction of laser beam is varied by 90° . The vessel for consolidation is filled with nitrogen so as to prevent the oxidization of the metal powder during laser irradiation.

The specification of the metal powder used is shown in Table 1. The metal powder is a mixture of 70% chromium molybdenum steel powder, 20% copper alloy powder and 10% nickel powder. The mean diameter of powder mixture is $d = 25 \mu\text{m}$. Since the powder layer is loaded under gravity action only, its bulk density is 4190 kg/m^3 [2].

The SEM image of the consolidated surface is shown in Fig. 2, and its property is summarized in Table 2. Partially molten powder and pores are clearly seen on the consolidated surface. The hardness of the consolidated surface is not uniform, and the hardness of partially molten powder is higher than that of fully molten powder. In a multifunction machine, such an area of instability can be cut with an end mill.

3. Experimental method

The experimental set up for laser assisted milling is schematically illustrated in Fig. 3. The laser beam used is a continuous CO_2 laser with a maximum power

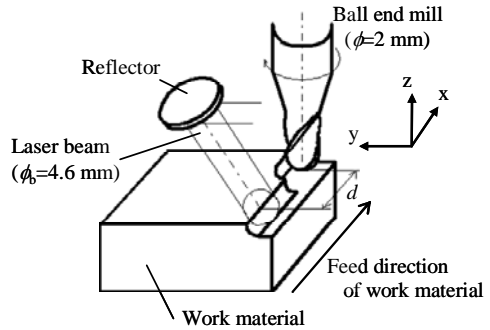

Fig.3 Experimental set up for laser assisted milling

of $P = 100 \text{ W}$. The laser beam is irradiated to the consolidated surface without focusing by the condenser; therefore, the beam diameter at the consolidated surface is $\phi = 4.6 \text{ mm}$. The laser beam is irradiated to the position of d against the cutting point. Hence, the work material is cut by the ball end mill after the surface is heated by laser beam irradiation.

The experimental conditions are summarized in Table 3. The work material used is a consolidated structure by the layered manufacturing equipment. A milling machine is used to perform the cutting test. Three components of cutting force are measured by piezo type dynamometer, on which the work material is mounted. The specific cutting force is calculated with the cutting force in feed direction F_y . The experiment is performed under a tool revolution of $N = 6000 \text{ rpm}$ due to the response of the dynamometer.

Table 3 Experimental conditions

Tool diameter	ϕ_t	2.0 mm
Helix angle		30 °
Revolution	N	6000 - 40000 rpm
Cutting speed	v	37.7 - 251 m/min
Feed speed	f	0.005 - 0.01 mm/tooth
Feed speed	F	120 - 400 mm/min
Axial depth of cut	A_d	1.0 - 1.2 mm
Radial depth of cut	R_d	0.2 mm
Laser power	P	70, 80, 95 W
Distance from irradiated area to cutting point	d	5, 10, 15 mm

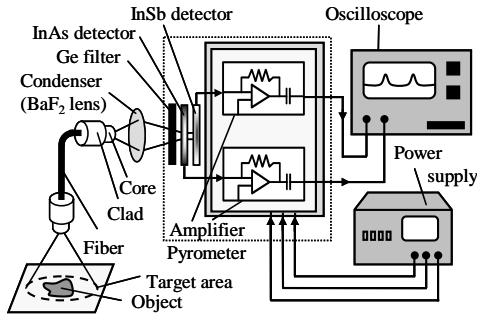

Fig.4 Schematic illustration of two-color pyrometer

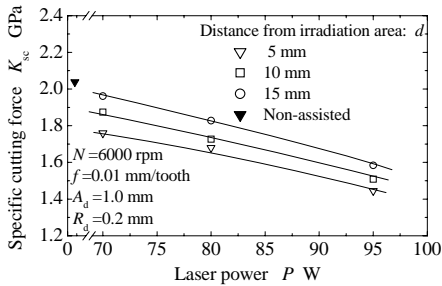

Fig.5 Influence of laser power on specific cutting force

The data obtained in laser assisted milling are compared to those in non-assisted milling.

A schematic illustration of the two-color pyrometer is shown in Fig. 4. It has almost the same structure shown in the authors' previous papers. The pyrometer is composed of an optical fiber and two types of infrared detectors; namely, an InAs detector and an InSb detector. The InAs detector was mounted in a sandwich configuration over the InSb detector, with each detector having a different range of acceptable wavelength. The laser beam cannot reach these detectors

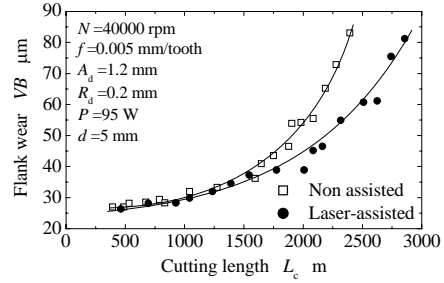

Fig.6 Effect of the laser assisted on tool flank wear

through a chalcogenide optical fiber whose transmittance range is 1–6.6 μm . The infrared energy radiated from an object is accepted by chalcogenide optical fiber and led to a two-color detector. It is converted into an electric signal and stored in digital memory. By taking the ratio of these two output voltages and using a calibration curve, the temperature of the irradiation area of the laser beam can be obtained. The fiber is horizontally fixed at the point where the cutting edge has finished cutting the work material. The distance between the surface of the flank face and the incidence face of the fiber tip is 1.5 mm.

4. Experimental results and discussion

4.1 Specific cutting force

The influence of the laser power on the specific cutting force is shown in Fig. 5. The result obtained under the condition of non-assisted milling is also shown. As is obvious from the graph, the specific cutting force with the laser assisted milling decreased with the increase of laser power, and was smaller without the laser assisted milling under all conditions. The specific cutting force decreased as the distance from the cutting point to the laser irradiation area was shortened. When the laser power is $P = 95$ W and the distance from the cutting point to the laser irradiation area is $d = 5$ mm, the specific cutting force is $K_{sc} = 1.4$ GPa, and 30% smaller than non-assisted milling. It is clear that the specific cutting force is influenced by the laser irradiation softening the surface of the work material.

4.2 Tool flank wear

The effect of the laser assisted milling of the work material on the tool flank wear under the condition of $P = 95$ W and $d = 5$ mm is shown in Fig. 6. A minimum tool wear of $VB = 25$ μm at $L_c = 400$ m was obtained in both conditions. When the flank wear was $VB = 80$ μm , the cutting length in the laser assisted

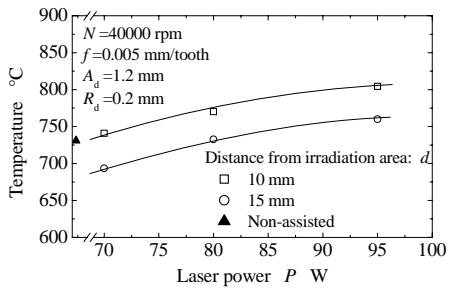

Fig.7 Influence of laser power P on tool temperature

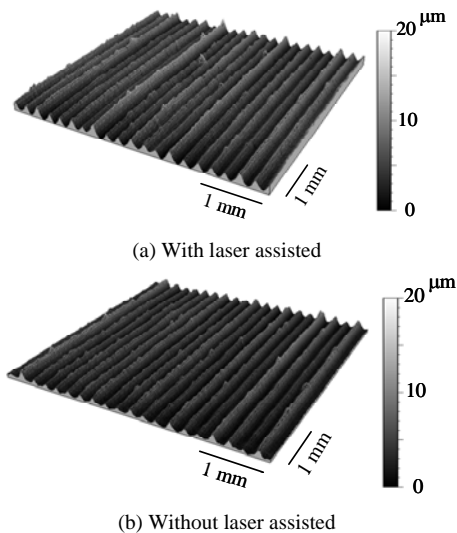

Fig.8 Comparison of the processed surface

milling is $L_c = 2860$ m and the progress of wear on the flank face was 20% slower than that without the laser assisted milling. This was due to the fact that the partially melted powder remaining on the surface was heated, and the surface of work material was softened.

4.3 Tool flank temperature

The influence of the laser power on tool flank temperature is shown in Fig. 7. The result obtained under the condition of non-assisted milling is also shown. As is obvious from the graph, the tool flank temperature increased with the increase of laser power; however, the temperature with the laser assisted milling was higher than that without laser assisted milling under almost all conditions. This was due to the fact that the energy irradiated to the work material was conducted to the tool.

Fig. 8 shows a three dimensional profile of the work surface after processing the end milling. The

surface with the laser assisted milling is rough compared with that without laser assisted milling. The surface roughness was $R_z = 7.0$ μm with laser assisted milling and $R_z = 6.0$ μm without laser assisted milling. This is due to the fact that the dimensional accuracy and surface finishing of the consolidated structure were influenced by the temperature rise on the tool flank.

4. Conclusion

The influence of the laser power and the distance from the cutting point to the laser irradiation area on machinability was investigated experimentally. The results show that the specific cutting force with the laser assisted milling decreased with the increase of laser power, and was smaller without the laser assisted milling under all conditions. The progress of wear on the flank face assisted with the laser beam irradiation was slower due to the softening of the consolidated structure and the melting of the powder which remained on the structure surface. The maximum temperature on the tool flank increased with the increase of laser power, and was larger without laser beam irradiation under almost all conditions.

References

- [1] S. Abe et al.: Milling-Combined Laser Metal Sintering System and Production of Injection Molds with Sophisticated Functions, *Proceedings of 11th ICPE*. (2006) 288-293.
- [2] T. Furumoto et al.: Study on the measurement of physical property in the metal powder for rapid prototyping, Proposal of the measurement of thermal conductivity and absorption of laser beam, *Journal of the Japan Society for Precision Engineering*, 73 (5) (2007) 558-562.
- [3] T. Ueda et al.: Thermal Behaviour of Cutting Grain in Grinding, *Annals of the CIRP*, 44 (1) (1995) 325-328.
- [4] T. Ueda et al.: The Temperature of a Single Crystal Diamond Tool in Turning, *Annals of the CIRP*, 47 (1) (1998) 41-44.



Tatsuaki FURUMOTO

received his B.S. and Ph.D. degrees from Kanazawa University in 1996 and 2006, respectively. Furumoto's research interests include dental therapy with laser irradiation, laser processing, and rapid prototyping.