

Molecular-dynamics studies on the shock-induced phase transition of a MgF₂ crystal

メタデータ	言語: eng 出版者: 公開日: 2017-10-03 キーワード (Ja): キーワード (En): 作成者: メールアドレス: 所属:
URL	https://doi.org/10.24517/00010949

This work is licensed under a Creative Commons Attribution-NonCommercial-ShareAlike 3.0 International License.



Molecular-dynamics studies on the shock-induced phase transition of a MgF_2 crystal

Kazume Nishidate and Mamoru Baba

Department of Electronic Engineering, Faculty of Engineering, Iwate University, Morioka 020, Japan

Tsutomu Sato

Department of Physics, Faculty of Science, Hirosaki University, Hirosaki 036, Japan

Kiyoshi Nishikawa

Department of Chemistry, Faculty of Science, Kanazawa University, Kanazawa 920, Japan

(Received 5 December 1994; revised manuscript received 17 April 1995)

The shock-induced phase transition of a MgF_2 crystal with the rutile structure was simulated by means of a molecular-dynamics (MD) calculation, where the simplified interatomic potential function was applied. We found that the rutile structure of a MgF_2 crystal is transformed to the cubic fluorite structure in several femtoseconds through both the static and the biaxial shock-compression processes of the MD calculation, in which the transition pressure at room temperature was successfully reproduced. Moreover, we revealed explicitly that the mechanism of the rutile-cubic phase transition is mainly due to the rotational motion of F^- ions surrounding the Mg^{2+} ion in the crystal.

I. INTRODUCTION

Transition metal compounds of RF_2 type such as MnF_2 , FeF_2 , CoF_2 , NiF_2 , and ZnF_2 all have the same rutile structure and belong to the D_{4h}^{14} ($P4_2/mnm$) space group symmetry. Because the crystal structure of all these crystals is isomorphic to those of TiO_2 (rutile) and SiO_2 (stishovite),¹⁻⁴ which is one of the most important materials on Earth, many investigations have been performed from both experimental and theoretical points of view. The MgF_2 single crystal also has the same rutile structure as the above compounds. However, contrary to these compounds, Mg is not a transition metal; namely, Mg^{2+} has no d electrons. Thus, the MgF_2 crystal has the strongest ionic bonding character among the RF_2 -type compounds mentioned above. Therefore, this crystal can be expected to have rather peculiar properties. It is very interesting how this difference in the bonding character of the crystal is effectively reflected in the physical properties, so that many studies on this crystal have been recently performed. We have already investigated the temperature dependence of the frequency shift and linewidth for the A_{1g} mode of this crystal by a lattice dynamical perturbative method, and have explained the role of anharmonicity in the temperature dependence of the A_{1g} mode Raman line.^{5,6}

Over the past few years, a considerable number of studies have been made on the pressure-induced structural phase transition of this crystal. Ming and Mangnana² experimentally investigated the high-pressure phase transition from the MgF_2 -I rutile to MgF_2 -II cubic (space group $Fm\bar{3}m$) structure, and estimated the transition pressure to be ~ 25 Gpa (250 kbar) at room temperature and ~ 20 Gpa (200 kbar) at high temperature (~ 1300 °C) by x-ray diffraction analysis. Pascual *et al.*⁷ reported the uniaxial-stress-dependent Raman-active modes of MgF_2

up to 0.7 GPa (7 kbar), and found the softening of the B_{1g} (Γ_3 :92 cm^{-1}) optical mode. Tossell⁴ theoretically studied the structure, stabilities, and phase transition of metal difluoride and dioxide using the modified electron gas (MEG) theory,⁸ and predicted that the rutile-cubic phase transition of a MgF_2 crystal occurs between 20 and 42 GPa. Vassiliou⁹ ultrasonically measured the elastic constants of a MgF_2 single crystal at room temperature up to 1 GPa, and concluded that the softening of the elastic constant $C_s = (C_{11} - C_{12})/2$ is not related to the pressure-induced transition of MgF_2 . Generally speaking, the lattice dynamics (LD) approach to the rutile-cubic phase transition has never provided the exact transition pressure of a MgF_2 crystal, since it is very difficult to describe accurately the pressure dependence of the elastic constants, the softening of the elastic constant C_s and Raman-active B_{1g} optical mode^{7,9} at extremely high pressures from the LD theory.¹⁰

On the other hand, the molecular-dynamics (MD) experiment is one of the most powerful means to investigate the mechanism of the displacement-type phase transition in the pressure-increasing process under high static pressure.^{11,12} Kusaba *et al.*¹³ simulated the shock-induced phase transition of a TiO_2 rutile crystal by applying the MD calculation, and discussed the mechanism of the rutile-fluorite phase transition from the anisotropic behavior of rutile-type compounds induced by uniaxial compression. Recently, Nga and Ong¹² studied the pressure-induced structural phase transition of MgF_2 by means of two different constant-pressure MD algorithms. They found the metastable structure under ~ 100 GPa and the distorted fluorite (CaF_2) structure under ~ 140 GPa, which is, however, more than four times greater than the experimental pressure, and proposed the model mechanism of this structural phase transition. In their MD simulation, they applied the rather complex Born-

Mayer-Huggins potential with the dispersion term calculated by the periodic *ab initio* Hartree-Fock method.¹⁴

Here we performed some shock-compression MD calculations of a MgF_2 crystal using a more simplified potential, and we successfully reproduced the transition pressure at room temperature for the first time, and gave a detailed explanation of the microscopic mechanism of this phase transition by visualizing the motion of F^- and Mg^{2+} ions. In Sec. II, we refer briefly to the procedures of the numerical method and the experimental conditions for this crystal, and discuss the optimization of the interaction potential parameters. In Sec. III, the comparison of the MD result with the theoretical or experimental results is performed, and the mechanism of the shock-induced phase transition of a MgF_2 crystal is analyzed in detail. In the final section, we summarize the conclusions derived from the MD calculations.

II. NUMERICAL EXPERIMENT

The principle of the classical molecular-dynamics (MD) calculation is based upon a numerical integration of the Newtonian equation of motion for atoms; presently common algorithms such as a differential equation in Verlet's manner¹⁵ for the equation of motion and an Ewald summation for the Coulombic interaction between the atoms are generally employed. Since the number of particles, temperature, and pressure are conserved in the MD calculation of the T - p ensemble (N , T , p constant), the MD simulation of the T - p ensemble of the crystal is a very useful and powerful tool for surveying the time development of the displacement-type phase transition induced by changing the pressure or temperature. Therefore, we performed the MD calculation of the MgF_2 ionic crystal to obtain the appropriate value of transition pressure and revealed the detailed mechanism of the pressure-induced phase transition in the high-pressure range.

The unit cell of a MgF_2 crystal includes 4 F^- ions and 2 Mg^{2+} ions and is explicitly shown in Fig. 1. The initial configuration of all ions in the basic MD cell was arranged to fulfill the crystallographic space group symmetry D_{4h}^{14} ($P4_2/mnm$), where the experimental lattice constants of the MgF_2 rutile crystal¹⁶ were used to specify the atomic coordinates. The basic MD cell we adopted is composed of 80 ($4 \times 4 \times 5$) MgF_2 rutile crystallographic unit cells. Thus, we trace the motion of 480 ions (160 Mg^{2+} , 320 F^-) in the basic MD cell imposing the periodic boundary condition. In numerically solving the equation of motion, we used $\delta t = 2$ fsec as the time increment, which is significantly small compared to the time scale of the vibrational motion of ions in the crystal.

Temperature and pressure are simply regulated by the forced scaling method. Namely, the particle velocities v_i are adjusted to maintain a constant temperature every ten time steps (20 fsec),¹⁷⁻²⁰ while the basic cell dimensions L_α ($\alpha = x, y, z$) as well as the basic cell angle are adjusted so as to balance the internal pressure tensor evaluated using the virial theorem with the external prescribed pressure tensor every ten time steps (20 fsec).^{11,13,20-22} Since the total kinetic energy of all

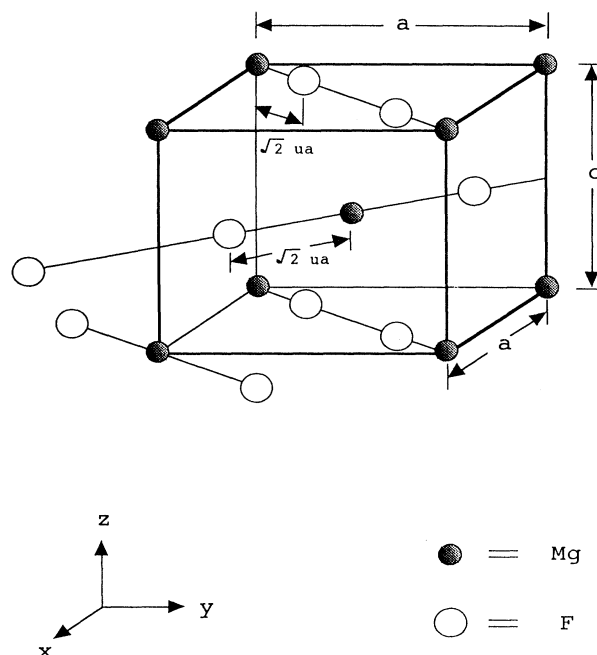

FIG. 1. Crystal structure of the tetragonal MgF_2 unit cell, where u is an atomic fractional coordinate.

particles included in the basic MD cell is equal to the corresponding thermal energy ($k_B T$), the system under consideration is immersed into a heat bath of prescribed temperature and pressure throughout all steps of the calculation, except the pressure-increasing steps.

The numerical simulation was explicitly performed as follows. The initial configuration of all ions was equilibrated at 300 K under 0.0001 GPa static pressure over the first 2000 time steps (4 psec). The prescribed pressure was increased sequentially every 1000 time steps (2 psec) as the shock compressive stress on the crystal up to 11 000 time steps (22 psec). The prescribed pressure was then increased to 80 GPa from 11 001 time steps and 120 GPa from 12 001 time steps (24 psec). The change in observed pressure is explicitly shown in Fig. 5(d). Adjustments to the prescribed temperature and pressure were carried out every ten time steps, as mentioned above, so that the observed temperature remains constant at around 300 K, except at the transition point, as shown in Fig. 5(e). The observed pressure is also constant between two successive shock-compressive points shown in Fig. 5(d). Namely, Figs. 5(d) and 5(e) clearly indicate that the control methods employed here are accurate enough to survey the shock-induced phase transition mechanism for practical use.

The MD experiment on a crystal is very difficult compared with that on liquid or glass materials, because the calculated crystallographic structure must satisfy the same space group symmetry as obtained by x-ray diffraction crystal analysis in the entire range of MD simulation. One of the most important factors is the potential function, as has often been pointed out. Since the atomic positions in the MD basic cell are expected to move around

considerably at the transition pressure, the potential field affecting the ions will also change markedly in the course of the phase transition. However, the most important and fundamental factor of the phase transition is the mechanism inducing the collective motion of ions rather than the microscopic form of the potential function itself. For the proper description of the two-body interaction in the extremely high-pressure region, there still remain many uncertainties even in the complex potential function of an ionic crystal, such as the Born-Mayer-Huggins function with dispersion terms. Therefore, we used a simplified two-body potential function^{11,21,23,24} without the dispersion terms for the completely ionic crystal to investigate the pressure-induced rutile-cubic phase transition of a MgF_2 crystal,

$$u_{ij} = \frac{z_i z_j}{r_{ij}} + f_0(b_i + b_j) \exp\left(\frac{a_i + a_j + r_{ij}}{b_i + b_j}\right), \quad (1)$$

where $f_0 = 1.0 \text{ kcal } \text{\AA}^{-1} \text{ mol}^{-1}$ represents only its magnitude; z_i , a_i , and b_i are the formal ionic charge, the ionic radius, and the ionic compressibility of atom i , respectively; and r_{ij} represents the distance between atoms i and j . In this equation, the first term is the long-range Coulomb interaction between two ions, and the second one represents the Gilbert-Ida short-range repulsion due to the overlap of the electron cloud of ions. This form of potential is generally reasonable for describing the various ionic crystals, and thus we must evaluate the optimal parameters for MgF_2 . We first choose the potential parameter sets, SX-I,²² which have been developed from the MS-I (Refs. 11 and 21) potentials to reproduce many stable crystal structures as well as the elastic constants of several typical atoms, and then obtain the new optimized potential parameter set by MD calculation which successfully reproduces the experimental physical values of a MgF_2 crystal even in the high-pressure region where the MD simulation was performed. We call this optimized set MF-II, as shown in Table I.

To analyze the calculated results from various points of view, we developed a general-purpose MD analyzing system called ANLZR,²⁵ which includes the program MXDORTO (Ref. 22) originally written by Kawamura as the MD calculation kernel. This system provides a machine-independent MD computational analyzing environment. The ANLZR program automatically creates numerical files of the variations of temperature, pressure, lattice constants, and mean squared displacement from the output files of the MXDORTO program, and the re-

sultant files are processed by scientific graphic tools to give, for example, Figs. 5 and 6. ANLZR also creates the sound and animation files in the *Mathematica* format,²⁶ so that we can directly observe the dynamic motion of the atoms after the MD simulation.²⁵ This is the most straightforward and effective way to analyze and visualize the calculated MD results of a crystal. All MD calculations were performed on the HP730 and HP715 (UNIX) computers.

III. RESULTS AND DISCUSSION

We carried out MD simulation of the 80 MgF_2 crystallographic unit cells with 480 ions. Then, we observed the shock-induced structural phase transition at 25 GPa at room temperature for the first time, and were able to analyze the detailed mechanism of the pressure-induced phase transition.

We observed a rotational motion of 6 F^- ions surrounding each Mg^{2+} ion in the unit cell, as shown in Fig. 2(a). This rotational movement of 6 F^- ions strongly

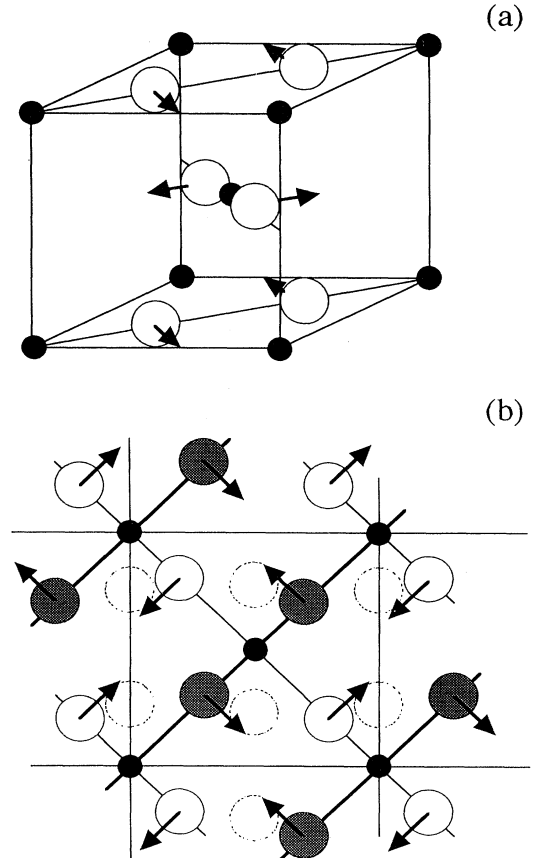

FIG. 2. (a) Shock-induced atomic movements in the $x-y$ plane of the initial MgF_2 -I rutile structure at the transition pressure. (b) Atomic displacements associated with B_{1g} optical mode, where the shaded and large white circles are F^- ions at the middle height and the bottom (or top) height in the MgF_2 -I unit cell, respectively, and the dotted circles indicate the final position of F^- ions after the transition.

TABLE I. The SX-I and the MF-II potential parameter sets of Eq. (1), where formal ionic charge Z , atomic weight w , formal ionic radius a , and formal ionic compressibility b are shown for Mg^{2+} and F^- ions.

		$Z(e)$	w	a (\AA)	b (\AA)
SX-I potential	Mg	+2.0	24.31	1.161	0.080
	F	-1.0	19.00	1.565	0.085
MF-II potential	Mg	+2.0	24.31	1.258	0.090
	F	-1.0	19.00	1.405	0.095

suggests the presence of the B_{1g} softening mode in Fig. 2(b) under the static compression process, and is similar to the shock-induced phase transition mechanism of a TiO_2 crystal with rutile structure to fluorite structure.¹³ The diagrams and the trajectories of calculated ions in the shock-compression process are also shown in Figs. 3 and 4, respectively. The position of F^- ions is described explicitly at some pressure points in Fig. 3, which shows that (1) before the phase transition, F^- ions fluctuate around their equilibrium position of the MgF_2 -I phase, as illustrated in Figs. 3(a)–3(g); (2) then F^- ions in Fig. 3(g) quickly dislocate to new positions shown in Fig. 3(h) corresponding to the fluorite structure. The process from Figs. 3(g) to 3(h) is exactly the phase transition at 25 GPa induced by the very high shock-compressive stresses; and (3) finally, after this transition, the positions of F^- ions change little, as shown in Figs. 3(h)–3(l). In Fig. 4, three-dimensional atomic displacement during phase transition is depicted in detail, and we can immediately

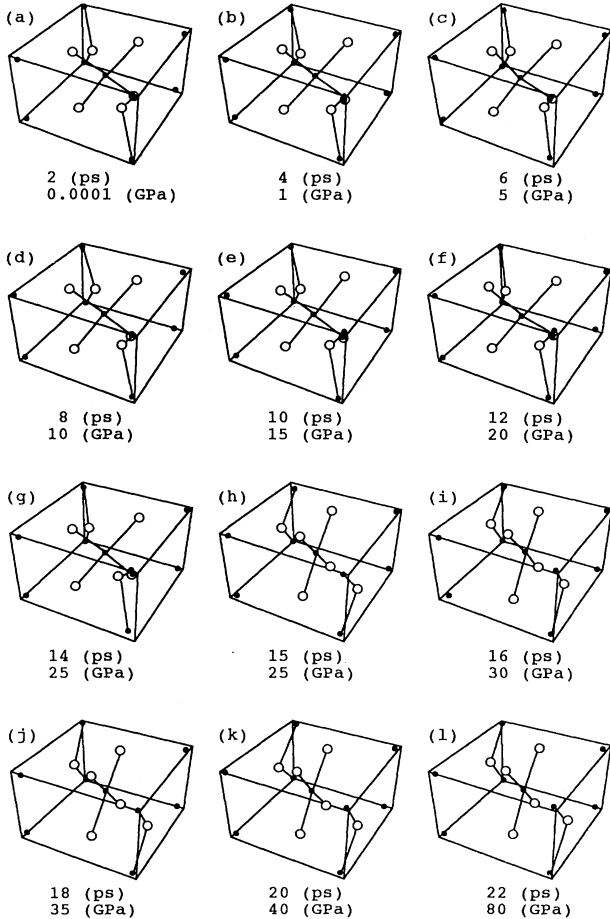

FIG. 3. Diagrams of a MD basic unit cell, where the white and black circles indicate F^- and Mg^{2+} ions, respectively. Each frame shows the time and pressure at which a MD simulation was performed. The quick dislocation rearrangements induced by shock-compressive stresses are observed in (g) and (h) (14 to 15 psec).

see the rotational motion of 6 F^- ions surrounding the Mg^{2+} ion. Due to this rotational motion, two F^- ions at the middle height of the MgF_2 -I unit cell are shared by the nearest-neighbor unit cells in the same x - y plane, as shown in Figs. 2, 3, and 4. Therefore, the six-folded Mg^{2+} ions of the rutile structure (MgF_2 -I) dynamically change into the eight-folded Mg^{2+} ions of the new cubic structure (MgF_2 -II) in a few femtoseconds due to the shock-induced structural phase transition.

In Fig. 5, we show the time development of several important physical quantities calculated every five time steps (10 fsec), all of which clearly display the shock-induced phase transition process at 25 GPa. The variation of the lattice constants (\AA) is shown in Fig. 5(a). The lattice constants a , b , and c of the MD calculation could be evaluated from the MD basic cell, including the $4 \times 4 \times 5$ MgF_2 -I unit cells, as

$$a_{\text{rutile}} = \frac{L_x}{4}, \quad b_{\text{rutile}} = \frac{L_y}{4}, \quad c_{\text{rutile}} = \frac{L_z}{5}, \quad (2)$$

where L_α ($\alpha = x, y, z$) is the dimension of the MD basic cell. Since the crystal structure becomes cubic after transition, the new crystallographic unit cell could also be calculated as

$$a_{\text{cubic}} = \frac{L_x}{4}, \quad b_{\text{cubic}} = \frac{\sqrt{2}L_y}{4}, \quad c_{\text{cubic}} = \frac{\sqrt{2}L_z}{5}. \quad (3)$$

The calculated lattice constant of the MgF_2 -II cubic unit cell is 4.5 \AA , in agreement with the experimental results for 30 GPa at room temperature (see Table II).² The slight differences from the experimental results are considered to be due to the small MD basic cell dimensions. Next, we focus on the noteworthy behavior of mean squared displacement (MSD) in Fig. 5. We observe in Fig. 5(b) that (1) there is a fluctuating behavior in MSD for F^- ions due to the B_{1g} softening optical mode prior to the transition; (2) after the transition, F^- ions continue to oscillate regularly around the new equilibrium position; and (3) a slight jumping motion of MSD was also observed at the transition point of MSD. The dynamic rotational motions of 6 F^- ions in the MgF_2 -I unit cell at 25 GPa cause the small jumping motion of the Mg^{2+} ions which quickly recover to the steady atomic positions in the MgF_2 -II structure.

Finally, we examine other physical quantities. The calculated molar volume in Fig. 5(c) agrees approximately with the observed molar volume (8.2845 cm^3/mol in a MgF_2 -I unit²). At the transition point, there are a small dip and relatively large peak in the time evolution curves of observed pressure and temperature, as shown in Figs. 5(d) and 5(e), respectively. These effects may be attributed to the extremely quick transition of the crystal structure in the MD calculation of the T - p ensemble. Namely, a new transition route from the rutile structure to the cubic structure, which is closely related to the B_{1g} optical mode, is instantaneously opened just before the phase transition. F^- ions move rather freely along this soft mode path, which induces the lowering of the observed pressure. This fast motion of F^- ions also causes the increase of the kinetic energy corresponding to the

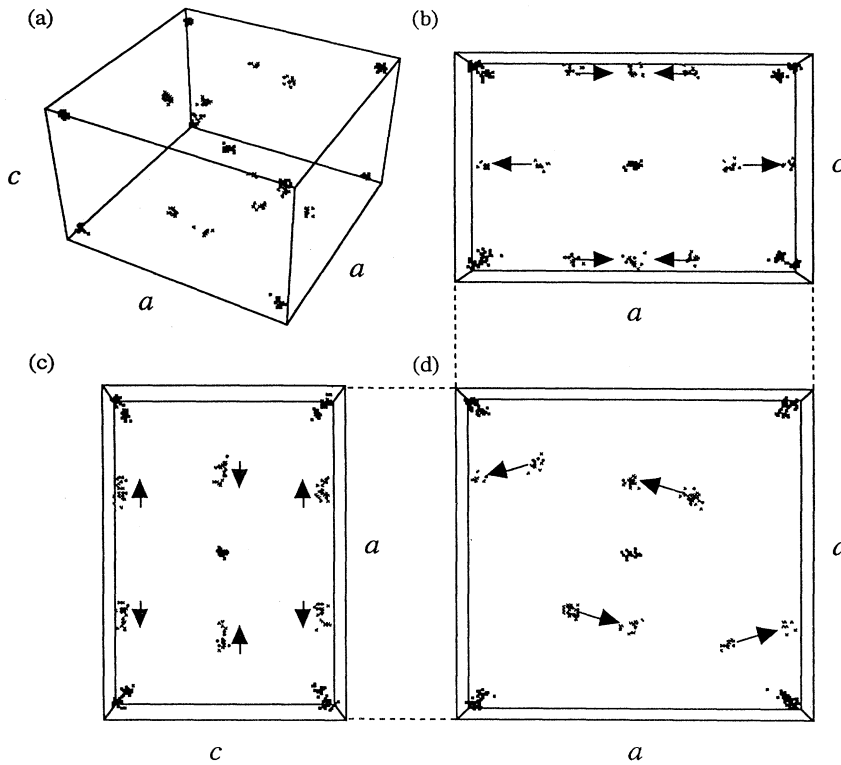

FIG. 4. Trajectories of ions in the shock-compression process, where a and c are the lattice constants and arrows show atomic movements during phase transition; (a) shows the trimetric projection view, (b) and (c) the side elevation views, and (d) the top view of the $\text{MgF}_2\text{-I}$ unit cell.

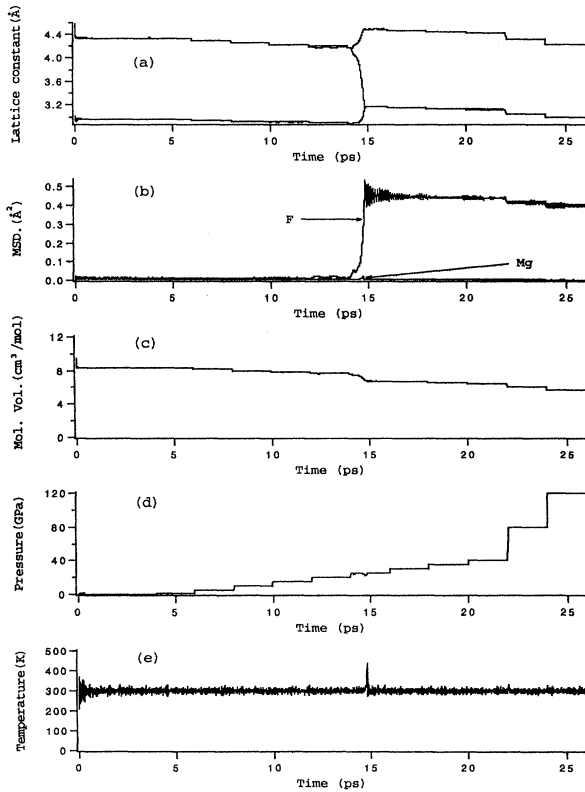

FIG. 5. Time evolution of several observed physical quantities in the uniform shock-induced phase transition, where (a) variation of lattice constants (\AA) in terms of the MD basic cell, (b) mean squared displacement of Mg^{2+} and F^- ions (\AA^2), (c) molar volume (cm^3/mol) in a $\text{MgF}_2\text{-I}$ unit, (d) pressure (GPa), and (e) temperature (K) are shown.

instantaneous increment of the temperature.

Since the rotational motions of 6 F^- ions which lead to the transition are perpendicular to the z axis, as shown in Fig. 4, the transition induced by the x - y biaxial shock-compression process can be expected to occur at a lower pressure. Therefore, we performed the x - y biaxial shock-compression MD calculation, where only the z axis pressure was conserved at 10 GPa during the pressure-increasing process. In the results shown in Fig. 6, we found the distorted fluorite structure and the transition pressure at 15 GPa in the x - y compression process, which is significantly smaller than at 25 GPa under the static condition. Contrary to the static compression experiment mentioned before, the fluctuating behavior in the MSD for F^- ions prior to the transition disappears due to the relatively smooth transition process induced by biaxial compression, as depicted in Fig. 6(b). At the transition point of MSD, we also observed a small jumping motion of Mg^{2+} ions, as shown in Fig. 6(b), and a small dip in the time evolution of pressure was observed in Fig. 6(c). The movement of 6 F^- ions in the $\text{MgF}_2\text{-I}$ unit cell at the transition point suggests the presence of the same transition mechanism in the static and x - y biaxial pressure-induced phase transitions. In the final stage of the MD calculation, the distorted $\text{MgF}_2\text{-II}$ crys-

TABLE II. The experimental lattice constants (\AA) of $\text{MgF}_2\text{-I}$ and $\text{MgF}_2\text{-II}$ crystals, where a and c are the lattice constants, and u is an atomic fractional coordinate (Ref. 2).

Structure	a (\AA)	c (\AA)	u
$\text{MgF}_2\text{-I}$	4.631	3.057	0.303
$\text{MgF}_2\text{-II}$	4.792		

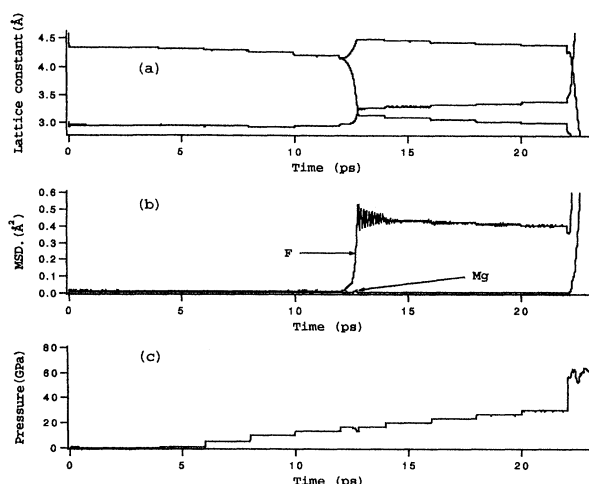

FIG. 6. Time evolution of several observed physical quantities in the biaxial shock-induced phase transition, where (a) variation of lattice constants (\AA) in terms of the MD basic cell, (b) mean squared displacement of Mg^{2+} and F^- ions (\AA^2), and (c) pressure (GPa) are shown.

tal structure was finally destroyed, where the axial pressure along the x and y directions was kept at 120 GPa and the axial pressure in the z direction was kept at 10 GPa.

IV. CONCLUSIONS

In this work, we investigated the pressure-induced phase transition of the MgF_2 crystal through the molecular-dynamics calculation using the optimized MF-

II potential, obtained an accurate value of the transition pressure, and revealed the microscopic mechanism of the phase transition under both the static and biaxial experimental conditions.

The pressure-induced phase transition of the MgF_2 -I to the MgF_2 -II structure at room temperature was, for the first time, reproduced at 25 GPa in the case of the static compression process. For the biaxial case, we found that the corresponding phase transition occurs at 15 GPa, which is lower than that in the static case. These results are consistent with the experimental ones.

We have found that, as a result of phase transition, the 6 F^- ions surrounding the Mg^{2+} ion move to new atomic positions, and thus the crystal structure transforms to the eight-coordinated MgF_2 -II system having the cubic structure. The small jumping motion of Mg^{2+} ions was revealed by the MSD measurements in the pressure-increasing process. We found that softening of the B_{1g} optical mode of the MgF_2 crystal is directly related to the dynamic rotational motion of 6 F^- ions around the z axis under the static shock-compression process of the MD calculation. The phase transition was also observed at lower pressure in the x - y biaxial compression process because of the ease of movement of ions in the x - y plane. Therefore we conclude that the mechanism of this phase transition from the MgF_2 -I to the MgF_2 -II structure is fundamentally the process induced by the softening of the typical optical mode.

ACKNOWLEDGMENTS

The authors are deeply indebted to Dr. T. Ikeda, Dr. Y. Kashiwaba, and Dr. T. Matsumoto for stimulating and helpful discussions. The authors are also grateful to T. Kondou, M. Motomiya, K. Tanaka, and K. Kodama for their assistance in computations.

- ¹ L. E. A. Jones and R. C. Liebermann, *Phys. Earth Planet. Inter.* **9**, 101 (1974).
- ² L.-C. Ming and M. H. Mangnana, *Geophys. Res. Lett.* **Jan.** **6**, 13 (1979).
- ³ W. H. Baur, *Acta Crystallogr. B* **32**, 2200 (1976).
- ⁴ J. A. Tossell, *J. Geophys. Res.* **85**, 6456 (1980).
- ⁵ K. Nishidate and T. Sato, *Phys. Rev. B* **46**, 13 773 (1992).
- ⁶ K. Nishidate, K. Nishikawa, M. Suhara, and T. Sato, *J. Phys. Condens. Matter* **5**, 4855 (1993).
- ⁷ J. Pascual, J. Camassel, P. Merle, B. Gil, and H. Mathieu, *Phys. Rev. B* **24**, 2101 (1981).
- ⁸ Y. S. Kim and R. G. Gordon, *Phys. Rev. B* **9**, 3548 (1974).
- ⁹ J. K. Vassiliou, *J. Appl. Phys.* **57**, 4543 (1985).
- ¹⁰ J. Pascual, J. Camassel, P. Merle, and H. Mathieu, *Phys. Rev. B* **15**, 2439 (1980).
- ¹¹ Y. Matsui and K. Kawamura, in *High-Pressure Research in Mineral Physics*, edited by M. H. Manghnani and Y. Syono (Terra/AGU, Tokyo/Washington, DC, 1987), p. 305.
- ¹² Y. A. Nga and C. K. Ong, *J. Chem. Phys.* **98**, 3240 (1993).
- ¹³ K. Kusaba, Y. Syono, and Y. Matsui, in *Shock Compres-*

- sion of Condensed Matter*, edited by S. C. Schmidt, J. N. Johnson, and L. W. Davison (Elsevier Science Publishers, British Vancouver, 1990), p. 135.
- ¹⁴ M. Catti, A. Pavese, R. Dovesi, C. Roetti, and M. Causa, *Phys. Rev. B* **44**, 3509 (1991).
- ¹⁵ L. Verlet, *Phys. Rev.* **159**, 98 (1967).
- ¹⁶ W. H. Baur, *Acta Crystallogr. B* **32**, 2200 (1976).
- ¹⁷ S. Tsuneyuki, M. Tsukada, H. Aoki, and Y. Matsui, *Phys. Rev. Lett.* **61**, 869 (1988).
- ¹⁸ L. V. Woodcock, *Chem. Phys. Lett.* **10**, 257 (1971).
- ¹⁹ D. Fincham and D. M. Heyes, *Adv. Chem. Phys.* **LXIII**, 546 (1985).
- ²⁰ K. Kawamura, in *Molecular Dynamics Simulations*, edited by F. Yonezawa, Springer Series in Solid State Science Vol. 103, (Springer, Berlin, 1992), p. 88.
- ²¹ Y. Matsui and K. Kawamura, in *Materials Science of the Earth's Interior*, edited by I. Sunagawa (TERRAPUB, Tokyo, 1984), p. 3.
- ²² K. Kawamura, JCPE program MXDORTO, P029 (1993), JCPE Office: c/o Japan Association for International

- Chemical Information (JAICI), Nakai Bldg., 6-25-4 Honkomagome, Bunkyo-ku, Tokyo 113.
- ²³ T. L. Gilbert, *J. Chem. Phys.* **49**, 2640 (1968).
- ²⁴ Y. Ida, *Phys. Earth Planet. Inter.* **13**, 97 (1976).
- ²⁵ K. Nishidate, Y. Fujimura, K. Nishikawa, and M. Suhara, *MathSource* (Wolfram Research), mathsource@wri.com, July, ItemNumber 0203-397 (1992). *MathSource CD-ROM* (1994).
- ²⁶ S. Wolfram, *Mathematica, A System for Doing Mathematics by Computer*, 2nd ed. (Addison-Wesley, Redwood City, CA, 1991).