

Efficacy of Monitoring Patient's Position during Neurosurgical Procedures: Introduction of Real-time Display and Record

Mitsuhiro HASEGAWA,^{1,2} Mohsen NOURI,^{1,+1} Hironori FUJISAWA,^{2,+2}
Yutaka HAYASHI,² Joji INAMASU,¹ Yuichi HIROSE,¹ and Junkoh YAMASHITA^{2,+3}

¹Department of Neurosurgery, Fujita Health University, Toyoake, Aichi;

²Department of Neurosurgery, Kanazawa University Hospital, Takara-machi, Kanazawa;

⁺¹Department of Neurosurgery, Razi Hospital, Zahedan University of Medical Sciences, Saravan, Iran (current affiliation);

⁺²Department of Neurosurgery, Fukui Prefectural Hospital, Fukui, Fukui-shi, Fukui (current affiliation);

⁺³Asanogawa Hospital, Kanazawa, Ishikawa (current affiliation)

Abstract

There are many reports on position-related complications in neurosurgical literature but so far, continuous quantification of the patient's position during the surgery has not been reported. This study aims to explore the utility of a new surgical table system and its software in displaying the patient's body positions during surgery on real-time basis. More than 200 neurosurgical cases were monitored for their positions intra-operatively. The position was digitally recorded and could be seen by all the members in the operating team. It also displayed the three-dimensional relationship between the head and the heart positions. No position-related complications were observed during the study. The system was able to serve as an excellent indicator for monitoring the patient's position. The recordings were analyzed and even used to reproduce or improve the position in the subsequent operations. The novel technique of monitoring the position of the head and the heart of the patients and the operating table planes are considered to be useful during delicate neurosurgical procedures thereby, preventing inadvertent procedural errors. This can be used to quantify various surgical positions in the future and define safety measures accordingly.

Key words: monitoring, operating table, position, real-time display

Introduction

Head and body positioning is one of the basic aspects of neurosurgical operations. Position-related complications such as peripheral neuropathy, cervical myelopathy, air embolism, and cerebral edema during the surgery have been discussed in the literature and various measurements have been proposed to reduce their occurrence,^{1,2)} though none is quantitatively described. The degree of flexion and extension of neck, its positional relationship with shoulders, and its angle of rotation are described in detail in the literature for different procedures. The positional relationship between the heart and the surgical field, which is considered to be an important factor in the positioning of the neurosurgical procedures,

has been only discussed empirically without any detailed virtual description. It is well understood that cerebral edema and the intracranial pressure is reduced by elevating the head and avoiding pressure to the jugular vein (i.e., reverse Trendelenburg position).³⁾ It is also noted that lowering the head and elevating the lower extremities as much as possible lowers the incidence of air embolism in the sitting position.⁴⁾ The patient's physique, neck length, and other factors for individual cases are left to the discretion of an individual surgeon. Monitoring systems for changes in the patient's position during radiotherapy has been described,^{5,6)} but a system for intraoperative monitoring of the heart and body positions during the neurosurgical procedures after draping has not been described yet. We have developed an operating table system that includes a software for digitally recording and

displaying body positions during surgery on a real-time basis. This helps in visualizing the changes in the position of the table even after draping and reproducing the position at a later stage.

Methods

This study was carried out at the Kanazawa University from February 2002 to February 2005 and at 2nd Educational Hospital of Fujita Health University from April 2008 to December 2013. A new operating table (MST-7200BXD, Mizuho Co. Ltd., Tokyo) was used accompanied by a software (M72D10) for digitally recording and displaying body positions during surgery on real-time basis and subsequently reproducing those positions in future operations (M72DRP10, Mizuho Co. Ltd.). The system was used for all neurosurgical operations after being approved by the university's ethics committee and obtaining informed consent from the patients.

Seven rotary and positional encoders were installed in respective cylinders inside the operating table (Fig. 1): Encoder 1 for the table up/down was installed at pantograph-shaped elevation cylinder, encoders 2 and 3 for table-sliding for rostro-caudal direction and right-left direction was installed in the bottom of the table top, encoders 4 and 6 for the angle of table top for transverse and longitudinal directions were installed in the connector panel, encoder 5 for the angle of back section was installed at the shaft of the back section, and encoder 7 for the angle of the leg section was installed at the shaft of the leg section. Each encoder converted the angular position and motion of the shaft/axle to digital codes and transmitted information at frequency of five times per second. Serial data of the heights of the table top, back section, leg section, and other components along with the angle data of the horizontal and vertical rotations were collected. These data were transferred to the display software (M72D10) installed in a personal computer (PC) connected to the operating table. All position data were recorded and saved as a separate file. The measurement errors of data from each encoder were estimated within ± 2 mm for section height and within ± 4 degree for angles. This recorded data would be considered as a reference for position of the same or another patient in future operations, which could be displayed as green color illustrations in the same screen simultaneously (Figs. 2c, 3d). Displayed body position would be corrected if it did not coincide with the previously recorded data of the same position or at the surgeon's discernment. In addition, the side and the front views of the operating table could be displayed in schematic images. They were displayed

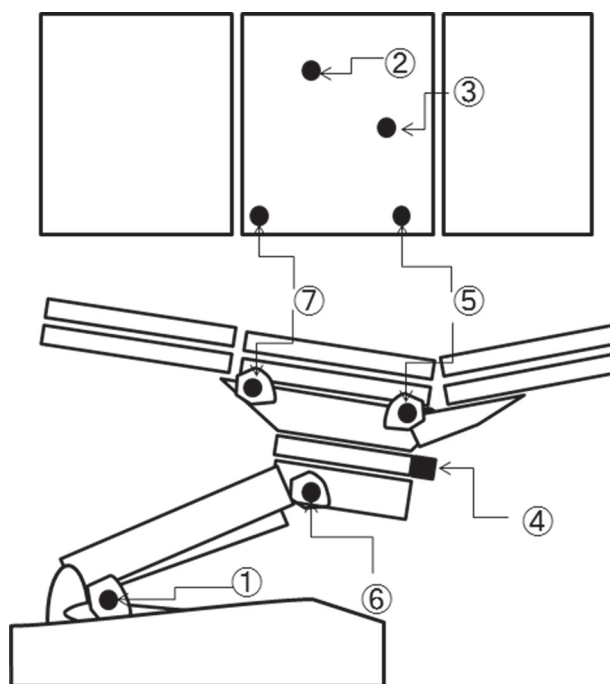

Fig. 1 Drawing showing the location of all encoders. Each encoder converts the angular position and motion of the shaft/axle to digital code. Encircled number 1: encoder 1 for table up/down, encircled number 2: encoder 2 for table-sliding for rostro-caudal direction, encircled number 3: encoder 3 for right-left direction, encircled number 4: encoder 4 for the angle of table top for transverse direction, encircled number 5: encoder 5 for the angle of back section, encircled number 6: encoder 6 for the angle of table top for longitudinal directions, and encircled number 7: encoder 7 for the angle of the leg section.

either as parallel lines or oblique lines in the form of cabinet drawing. The oblique lines were along a line that would intersect the Y-axis (head-clamp axis) at an angle of 30 degrees (Fig. 2d). This angle could be changed from 0 degree to 90 degrees.

The central point of the head (intersection of the mid-sagittal plane with inter-meatal line) and the position of the heart (right atrium) were recorded for each case. As a result, characteristics of the operating table and the position of the heart and the head could be displayed on an external monitor. The spatial relationships between the reference points could be determined by drawing vertical lines from the central points of the head and the heart towards the back section of the operating table. The flashing frequency of the heart position indicator was once every 5 data collection (i.e., once per second) whereas that of the head position indicator was once every 15 data collection (i.e., once every 3 seconds) (Figs. 2c, d, 3d).

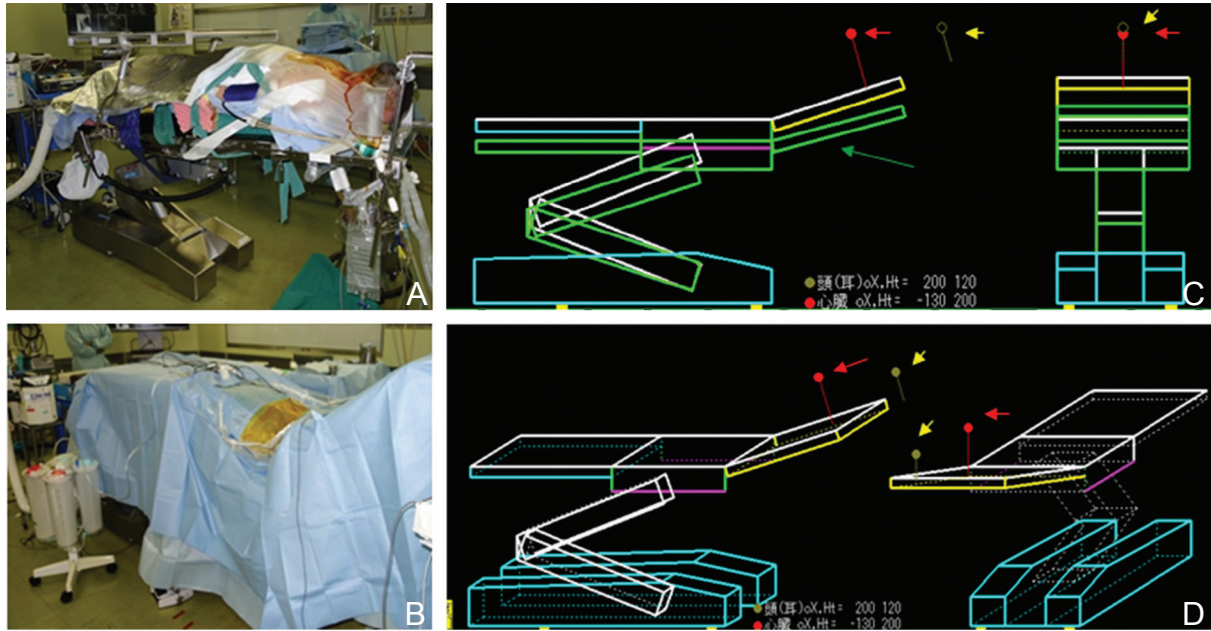

Fig. 2 A 65-year-old man in prone position for osteoplastic laminotomy before (A) and after (B) draping. Lateral (C) and oblique (D) views of his position are monitored continuously during surgery, which can be changed by pushing a function key. *Yellow circles* (indicated by *yellow arrows*) show head position, and *red circles* (indicated by *red arrows*) show heart position. *Green arrow* indicates reference position reproduced from the data obtained from the record of a former similar operation.

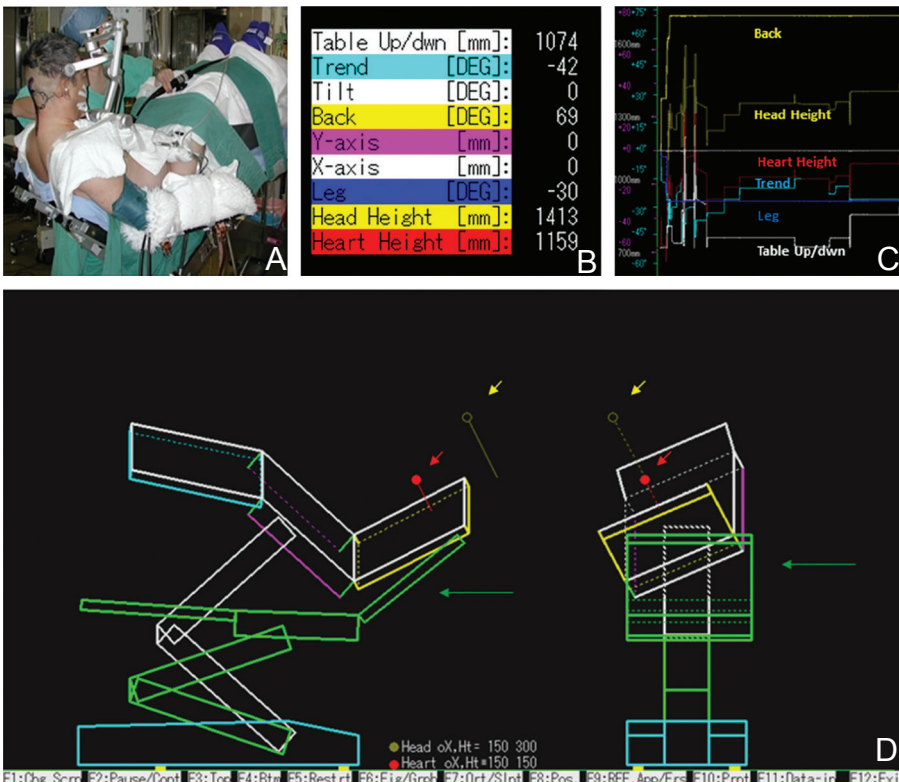

Fig. 3 A: A 43-year-old man in sitting position for a posterior fossa tumor (case 2). B: Numerical position data are demonstrated by a computer connected to the table. Each abbreviation in B is described as follows. Table up/down: height (mm) of table top, Trend: the angle (degree) of table top for longitudinal direction, Tilt: the angle (degree) of table top for transverse direction, Back: the angle (degree) of back section, Y-axis: the length (mm) of table-sliding for rostro-caudal direction, X-axis: the length (mm) of table sliding for right-left direction, and Leg: the angle (degree) of the leg section. Monitoring of the table was performed throughout the operation, displayed as line chart (a part of early phase of this case including the position setting is displayed as line chart in C). The color of each line is matched to that of the position data respectively. D: A representative diagram showing the front and lateral views of the table. *Green arrows*: reference position, *red arrows*: heart position, *yellow arrows*: head position.

Results

During the time course of the study, the system was used in more than 200 neurosurgical cases and no complications were observed. The table had advantage over the previously existing table (M72-7200BX) in terms of head elevation, vertical rotation, and monitoring system (Table 1). Showing the images in lines at different angles was useful in adding depth to the depicted images. In this manner, the images perceived on monitor are very realistic to the operating team. With the help of data-collecting software different operative views (e.g., superior view) could be obtained.

The system was able to serve as an excellent indicator for monitoring patient's position. Body position that had hitherto been described empirically or subjectively was displayed in actual numerical values as well as graphical form on real-time basis (Figs. 2, 3, detail described later). Previous body positions were superimposed on the screen and these could be referred to during the surgery for comparison. As a result of improvement in the upward and downward motion range, the head was able to be elevated while reducing the pressure difference between heart and surgical field. Acquired data for different positions are summarized in Table 2.

Table 1 Differences between the old and new operating table

Table	Elevation (mm)	Vertical rotation	Horizontal plate	Back plate	Monitor functions
Existing table MST-7200BX	480–1,100	20 degrees above head, 45 degrees below head	30 degrees in each direction of left and right	90 degrees up 30 degrees down	None
Newly developed operating table MST-7200BXD	510–1,300	20 degrees above head, 60 degrees below head	30 degrees in each direction of left and right	90 degrees up 30 degrees down	Provided

Table 2 Angle and height of four operative positions evaluated in this study

Position (approach)	Table up/down (mm)	Trend (Deg)	Tilt (Deg)	Back plate (Deg)	Y-axis (head-leg) (mm)	X-axis (right-left) (mm)	Leg plate (Deg)	Head height (mm)	Heart height (mm)
Supine (pterial)	678 ± 28.25	0.5 ± 0.87	0 ± 0	10.6 ± 2.01	0 ± 0	-0.8 ± 0.49	0 ± 0	981.6 ± 25.25	933.8 ± 38.36
Lateral (retrosgmoid)	626.2 ± 26.64	-2.4 ± 2.32	0 ± 0	17.6 ± 2.69	-4 ± 4	0 ± 0	0 ± 0	939.4 ± 39.46	946 ± 45.18
Prone (cervical spine)	658.8 ± 15.87	6.2 ± 1.71	0 ± 0	17.8 ± 2.52	-3.6 ± 3.6	-11.6 ± 11.6	0 ± 0	1,040.6 ± 6.44	997 ± 57.4
Sitting position	859.4 ± 48.9	-29 ± 1.52	0 ± 0	66.2 ± 3.61	0 ± 0	0 ± 0	-14.8 ± 5.07	1,368.33 ± 95.69	1,065 ± 46.32

Data of 5 cases were randomly extracted and analysed for each group. Data are presented as mean ± standard error. Deg: degree, mm: millimetre.

Illustrative Cases

I. Case 1

A 54-year-old man was operated in prone position for cervical laminoplasty (Fig. 2a). After draping, almost no information about patient position can be obtained (Fig. 2b). With this monitoring system, lateral and oblique views of his position were obtained intra-operatively (compare Fig. 2c with 2d) while head and heart positions were regularly assessed. Some inadvertent changes in position were immediately corrected. Post-operative course was uneventful without complications.

II. Case 2

A 43-year-old man was operated for posterior fossa huge hemangioblastoma in sitting position (Fig. 3a). Various body positions were displayed numerically (Fig. 3b) or in schematic images (Fig. 3d). Monitoring of the table was performed throughout the operation and displayed as a line chart (a part of the line chart is shown in Fig. 3c). The head position in relation to the heart was constantly observed and head position would be changed accordingly to prevent air embolism. The head height ranged from 117 cm to 158 cm, and the height-difference between head and heart position ranged from 27 cm

to 31 cm during the operation. No complications happened and the patient made a full recovery from the operation.

III. Case 3

A 17-year-old boy with rapid regrowth of pineal immature teratoma was treated by two-staged right and left paramedian transtentorial and supracerebellar approaches in sitting position. At the first stage, the height difference between head and heart was 31 cm, and small amount of air emboli was detected during craniotomy procedure (Fig. 4, the position is depicted in green color). Using this position as a reference, we performed the second stage operation successfully in a better position and without any complications (the difference between head and heart position was reduced to 25 cm). No air emboli were detected during the second operation.

Discussion

As physiologic parameters such as blood pressure, heart rate, central venous pressure, and oxygen satu-

ration are monitored continuously during surgery, we believe that monitoring of body positions is also essential. Patient position is important for surgeons, anesthesiologists, nurses, and other members of the operating team. Monitoring patient position is currently used in radiosurgery where the precise location of the target is the basis for treatment. Johnson et al. reported the use of “electronic portal images” and “digital video images” in formulating the position of the patient.⁵⁾ These techniques are used for monitoring changes in position and hence, minimizing the set up errors for radiotherapy. Similarly, Rogus et al. used photogrammetry method for positioning their patients actively and monitoring patient’s motion passively during radiotherapy treatment.⁶⁾ The system introduced here is different in that it uses the data gained from the operating table’s components in serial manner thereby, outputting on a real-time basis.

The position of head and heart is always important for delicate neurosurgical procedures as it affects cerebral perfusion and intra cranial pressure.⁷⁾ The sitting position and other positions in neurosurgery

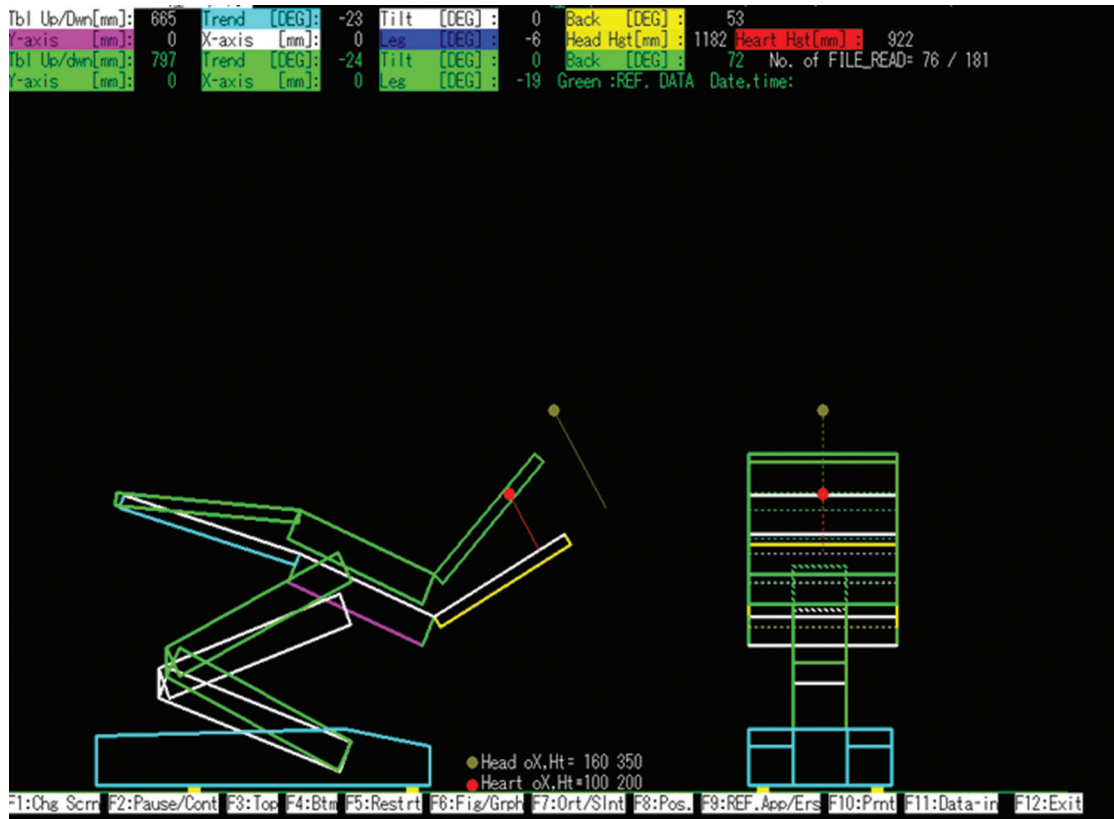

Fig. 4 Monitoring during sitting position for paramedian supra-cerebellar approach to a pineal region tumor. Data registration was used in the second operation to improve the position by reducing height difference between head and heart and eliminating air emboli during the surgery. *Green position*: the position at the first operation, *red dot*: heart position, *yellow dot*: head position.

exert variable impacts on the anesthesia.^{1,8)} The position of the patient during the surgery is also very important for the paramedical staff especially nurses assisting in the surgery.⁹⁾ The principles of (a) visualizing the patient position digitally, (b) checking the body position changes by all members of the team, and (c) evaluating and reproducing the previously used positions were successfully accomplished by using the system.

This is possible for the first time to *quantify* the relations between different indices (e.g., height difference between surgical field and heart) and a certain outcome (e.g., risk of air embolism). This device may also help define the *safe* limits and the danger zones for each part of surgical positioning (e.g., degree of head elevation). When various positions are described in the literature, the reader cannot exactly reproduce the same position and this reduces the reproducibility of the positioning and consequently the surgical exposure and safety. With this device, detailed positioning can be described in numbers and reproduced in exact form.

Finally, this surgical bed can be useful when an intra-operative change in position is required for example:

1. Spinal diseases: after decompression we may change the position to do fixation and fusion in the optimal position.

2. Skull base or vascular lesions: when deeper part of the lesion is out of view, a change in position (usually rotating the patient ipsi- or contra-laterally) can be helpful.

3. Trauma or posterior fossa surgery: any swelling in the brain or sinus bleeding can be controlled by elevating the upper part of the table. Air embolism detected on echo-cardiography can be addressed by depressing the head of the table.

Like any other newly introduced technology, we should expect some limitations for this table. The system is mechanical and computer based and may err while functioning, although no such problems were observed during our study. On the other hand, relying on this system as an indirect indicator of appropriate intra-cranial pressure or bleeding might be misleading as other elements of position are also important in addition to the position of the head and heart. For instance, the degree of flexion and extension of the neck, and head rotation angle are not currently monitored by the system and require further development. Furthermore, bleeding and intra-cranial pressure during the surgery involve many other factors in addition to the position of the patient.

A novel technique of monitoring the body position during critical neurosurgery procedures incorporating head-heart relationship can reduce the procedural errors and benefit patient's outcome. Further studies to use this table in reproducing surgical procedures and to define safety measures are warranted.

Conflicts of Interest Disclosure

The authors declare that the article content was composed in the absence of any commercial or financial relationships that could be construed as a potential conflict of interest.

References

- 1) Porter JM, Pidgeon C, Cunningham AJ: The sitting position in neurosurgery: a critical appraisal. *Br J Anaesth* 82: 117–128, 1999
- 2) Schwartz DM, Drummond DS, Hahn M, Ecker ML, Dormans JP: Prevention of positional brachial plexopathy during surgical correction of scoliosis. *J Spinal Disord* 13: 178–182, 2000
- 3) Rolighed Larsen JK, Haure P, Cold GE: Reverse Trendelenburg position reduces intracranial pressure during craniotomy. *J Neurosurg Anesthesiol* 14: 16–21, 2002
- 4) Mirski MA, Lele AV, Fitzsimmons L, Toung TJ: Diagnosis and treatment of vascular air embolism. *Anesthesiology* 106: 164–177, 2007
- 5) Johnson LS, Milliken BD, Hadley SW, Pelizzari CA, Haraf DJ, Chen GT: Initial clinical experience with a video-based patient positioning system. *Int J Radiat Oncol Biol Phys* 45: 205–213, 1999
- 6) Rogus RD, Stern RL, Kubo HD: Accuracy of a photogrammetry-based patient positioning and monitoring system for radiation therapy. *Med Phys* 26: 721–728, 1999
- 7) Rosner MJ, Coley IB: Cerebral perfusion pressure, intracranial pressure, and head elevation. *J Neurosurg* 65: 636–641, 1986
- 8) Rozet I, Vavilala MS: Risks and benefits of patient positioning during neurosurgical care. *Anesthesiol Clin* 25: 631–653, x, 2007
- 9) St-Arnaud D, Paquin MJ: Safe positioning for neurosurgical patients. *Can Oper Room Nurs J* 27: 7–11, 16, 18–19 passim, 2009

Address reprint requests to: Mitsuhiro Hasegawa, MD, PhD, Department of Neurosurgery, Fujita Health University Hospital, 1-98 Dengakugakubo, Kutsukake, Toyoake, Aichi 470-1192, Japan.
e-mail: mhasegawa-nsu@umin.ac.jp