

Determination of 1-nitropyrene in low volume ambient air samples by high-performance liquid chromatography with fluorescence detection

メタデータ	言語: eng 出版者: 公開日: 2017-10-04 キーワード (Ja): キーワード (En): 作成者: メールアドレス: 所属:
URL	http://hdl.handle.net/2297/17576

1 *Short Communication*

2

3 **Determination of 1-nitropyrene in low volume ambient air samples by HPLC**
4 **with fluorescence detection**

5

6

7 Takanori Ohno, Akira Toriba *, Takayuki Kameda, Ning Tang, Kazuichi Hayakawa

8

9

10 Graduate School of Natural Science and Technology, Kanazawa University, Kakuma-machi,
11 Kanazawa 920-1192, Japan

12

13

14

15

16 *To whom correspondence should be addressed.

17 E-mail address: toriba@p.kanazawa-u.ac.jp

18

1 **Abstract**

2

3 To measure the actual exposure of a person to 1-nitropyrene (1-NP) in airborne particulate
4 matter, it is considered more accurate to collect air samples with a portable air sampler than to
5 sample at a fixed location. However, because the portable samplers can sample only small volumes,
6 a sensitive method is needed to analyze the compounds that are collected on a filter. Here we
7 describe a high-performance liquid chromatographic (HPLC) method with fluorescence detection
8 that is sensitive and precise enough for use with portable air samplers. The developed
9 column-switching system successfully removed the interfering substances in the samples with only
10 a simple pretreatment. To improve the precision of the measurement, deuterated 1-NP was used as
11 an internal standard, and it eluted immediately prior to 1-NP with sufficient resolution (R_s , 1.50).
12 The detection limit was 0.32 fmol/injection, and the calibration range was from 2 to 100 fmol. The
13 proposed method was applied to determining 1-NP in fine airborne particulate matter (PM_{2.5}) at two
14 sites with low pollution levels. 1-NP was detected in all samples at concentrations in the low
15 fmol/m³ range. The proposed method has enough sensitivity and precision to determine 1-NP in the
16 limited air volume of the portable sampler.

17

18 *Keywords:* 1-nitropyrene; HPLC; fluorescence detection; airborne particulate matter

1 **1. Introduction**

2

3 Nitropolycyclic aromatic hydrocarbons (NPAHs) are hazardous environmental pollutants.
4 They are produced by both primary sources such as diesel vehicle exhaust [1] and by secondary
5 reactions of polycyclic aromatic hydrocarbons (PAHs) with nitrogen oxides and/or hydroxyl
6 radicals in the atmosphere [2]. Several NPAHs such as dinitropyrenes exhibit strong
7 carcinogenicity/mutagenicity [3, 4]. Among NPAHs, 1-nitropyrene (1-NP) is one of the most
8 abundant NPAHs in the atmosphere and in diesel exhaust particles and has been proposed as a
9 chemical marker for diesel exhaust [5, 6]. A large portion of NPAHs are associated with fine
10 airborne particulates with aerodynamic diameters less than 2.5 μm ($\text{PM}_{2.5}$). In addition, fine
11 particles ($\text{PM}_{2.5}$) themselves are of great health concern because they can easily reach pulmonary
12 alveoli [7]. Exposure to $\text{PM}_{2.5}$ has been associated with increased human health risk such as
13 mortality and morbidity [7].

14 Personal air monitoring, in which a person wears a small air sampler on the body, can more
15 accurately characterize human exposure than stationary ambient air monitoring, because individuals
16 have such varied activity patterns and exposures. Although previous studies have focused on
17 atmospheric concentrations of NAPHs, there is now growing interest in personal exposure to
18 NPAHs. Portable air samplers are typically small battery-powered devices that collect only a small
19 volume of air (e.g., 2 – 4 m^3), even during a 24-hour period, on a filter. However, this sample size is
20 presently insufficient for NPAH monitoring in the general population with low exposure level. A
21 reliable and sensitive technique for the quantification of NPAHs from the $\text{PM}_{2.5}$ in 1 – 2 m^3 of air
22 sample volume is required for this approach.

23 Scheepers et al. have applied gas chromatography-mass spectrometry (GC-MS) or GC-MS/MS
24 methods for personal exposure monitoring of 1-NP and its sensitivity was enough for the
25 assessment of occupationally exposed workers [8-10]. However, these methods require laborious
26 pretreatment steps including solid phase extraction, reduction of 1-NP to its amino analogue and
27 derivatization prior to GC-MS (/MS) analysis. On the other hand, high-performance liquid
28 chromatography (HPLC) methods with fluorescence, chemiluminescence and tandem MS detection
29 have been developed for the analysis of high volume ambient air samples and standard reference
30 materials, and these methods include on-line clean-up and reduction steps [11-14]. Therefore,
31 HPLC methods would be more preferable for routine analysis of 1-NP for personal exposure

1 monitoring than GC methods. The HPLC-tandem MS method is an accurate method but requires
2 expensive instrumentation not accessible to many researchers. The objective of this study was to
3 develop an analytical method by HPLC with fluorescence detection for determination of 1-NP in
4 low volume ambient air samples, which would make it possible to monitor personal exposure to
5 1-NP.

6 7 8 **2. Experimental**

9 *2.1. Chemicals*

10 1-NP was purchased from Sigma-Aldrich (St. Louis, MO, USA) and perdeuterated 1-NP
11 (1-NP- d_9) as an internal standard was obtained from C/D/N Isotopes Inc. (Quebec, Canada). Water
12 was obtained from a Milli-Q water purification system (Millipore, Bedford, MA, USA). All other
13 chemicals and solvents used were of analytical reagent grade from Wako.

14 15 *2.2. HPLC system and conditions*

16 The HPLC system, including a FCV-12AH six-port valve (Shimadzu, Kyoto, Japan), is
17 illustrated in Fig. 1 and consists of a LC-10AD pump (pump 1, Shimadzu), one L-6200 pump
18 (pump 2, Hitachi, Tokyo, Japan), a LC-10AD VP pump (pump 3, Shimadzu), a Rheodyne model
19 7125 injector (20 μ L loop), a DGU-14A degasser (Shimadzu), a 2475 fluorescence detector (Waters,
20 Tokyo, Japan), and a CR-7A-plus integrator (Shimadzu). The system consists of five HPLC
21 columns, a guard column (Cosmosil 5C18-MS-II; 4.6 mm i.d. \times 10 mm, Nacalai Tesque, Kyoto,
22 Japan), a clean-up column (Cosmosil 5C18-MS-II; 4.6 mm i.d. \times 50 mm), a concentration column
23 (Spheri-5 RP-18; 4.6 mm i.d. \times 30 mm, Chemco, Tokyo, Japan), a reduction column (NPPak-RS;
24 4.0 mm i.d. \times 10mm, JASCO, Tokyo, Japan) and a separation column (Cosmosil 5C18-AR- II ; 3.0
25 mm i.d. \times 250 mm, Nacalai). The reduction column was kept at 80°C in a CTO-2A column oven
26 (Shimadzu) and the guard column, the clean-up column, the concentration column, and the
27 separation column were kept at 40°C in a CTO-10AS VP column oven (Shimadzu). The mobile
28 phases and the flow rates were as described in Fig 1. The excitation (λ_{ex}) and emission (λ_{em})
29 wavelengths were 360 and 430 nm, respectively. The column-switching sequence used is shown in
30 Fig. 2. The interfering substances which elute faster or later than analytes from the clean-up column
31 were discarded and a fraction of only the reduced analyte and internal standard were quantitatively

1 transferred to the separation column.

2

3 2.3. *Sample collection*

4 According to our previous report [15], airborne particulate matter, both PM_{2.5} and PM_{10-2.5}
5 fractions were collected. Residential indoor and suburban outdoor filter samples were collected for
6 24 h (about 2 m³) in a house in Hakusan city (Ishikawa, Japan) and on the veranda of a building of
7 Kanazawa University (Kanazawa, Ishikawa, Japan), respectively. The residential indoor samples (n
8 = 3) were collected in the primary living area, not bedroom area where the participant spent the
9 most time. The suburban outdoor samples (n = 4) were collected on a veranda away from the
10 roadway and parking lot. The filter samples of the PM_{2.5} fraction were used to determine 1-NP.

11

12 2.4. *Sample preparation*

13 The procedures of the sample extraction are described in Fig. 2. After adding 1-NP-*d*₉ as
14 internal standard, filter samples were ultrasonically extracted twice with benzene/ethanol (3/1, v/v).
15 After the addition of dimethylsulfoxide (DMSO), the extract was placed under a stream of nitrogen
16 until the benzene-ethanol was completely evaporated. The resulting DMSO solution was mixed
17 with acetonitrile, and then filtered through a centrifugal filter (Ultrafree-MC, Millipore) of 0.45 μm
18 pore size.

19

20 2.5. *Quality assurance/quality control (QA/QC)*

21 QA/QC of the analysis was studied by replicate analysis of a pooled extract from the filter
22 samples. The extract was divided into constant fractions corresponding to an extract from about 2
23 m³ of airborne particulates, and the fractions were spiked at two concentrations of 2.5 and 25 pmol
24 L⁻¹ of 1-NP. The concentrations of 1-NP were quantified from peak area ratio of the 1-NP to
25 1-NP-*d*₉.

26

27

28 **3. Results and discussion**

29

30 The nitro-group of NPAHs needs to be reduced to convert the NAPHs to their corresponding
31 amino derivatives to obtain fluorescent derivatives of the analytes [11]. To simplify the reduction

1 step, columns packed with catalytic metals that have long lifetimes have been used.
2 Platinum/rhodium (Pt/Rh)-coated alumina showed a high efficiency of reducing NPAHs and was
3 applied to the detection of 1-NP with fluorescence and chemiluminescence detection [12, 13, 16]. In
4 our previous study, a large fraction of the eluate from the clean-up column was introduced into the
5 separation column to analyze 15 NPAHs which have a wide range of hydrophobicities. Therefore,
6 the clean-up column had little effect on removing substances that interfere with the detection of
7 NPAHs, and the system required laborious pretreatments such as washing with sodium hydroxide
8 and sulfuric acid and chemiluminescence detection, which has a higher specificity than fluorescence
9 detection [13]. In this study, switching only the 1-NP fraction to the concentration and separation
10 columns removed the interfering substances that elute from the clean-up column before and after
11 the analytes. Figure 3 shows representative chromatograms of the standard solution with the analyte
12 and the internal standard (A), and a PM_{2.5} sample of the indoor air (B). The peaks of the analyte and
13 internal standard were free from any interfering peaks, and the components in the real sample
14 treated without complicated pretreatment steps were effectively removed by the column switching.

15 Stable isotope-labeled compounds are excellent internal standard for MS (-MS) detection, not
16 generally for optical detection methods such as fluorescence detection. Perdeuterated PAHs have
17 been used for internal standards with fluorescence detection, since they usually elute immediately
18 before the non-deuterated PAHs with baseline resolution on polymeric ODS columns and they have
19 nearly the same fluorescence characteristic as the non-deuterated PAHs [17, 18]. Further, we
20 demonstrated that perdeuterated monohydroxylated PAHs (OHPAHs) exhibited characteristics
21 similar to those of the internal standards for OHPAH analysis in human urine [19, 20]. In this study,
22 we used for the first time perdeuterated 1-NP (1-NP-*d*₉) as an internal standard for fluorescence
23 detection, and the amino derivative of 1-NP-*d*₉ was well separated from that of 1-NP with sufficient
24 resolution (R_s , 1.50) on the separation (polymeric ODS) column.

25 The QA/QC was evaluated by measuring parameters as recovery, linearity, sensitivity,
26 repeatability and reproducibility. The recoveries of 1-NP (mean \pm SD, 88 \pm 4%) and 1-NP-*d*₉ (86 \pm
27 4%) in the sample preparation step were almost identical. No 1-NP was detected in the filter blank
28 (n=3). These results show that 1-NP-*d*₉ is an excellent internal standard for analysis of 1-NP. A
29 calibration curve was constructed using solutions containing 1-NP as a standard and 1-NP-*d*₉ as an
30 internal standard. Good linearity of the calibration curve ($r^2 > 0.999$) was obtained when the
31 amounts of the injected sample were in the range of 2 to 100 fmol. The detection limit was obtained

1 by duplicate analysis of 2 fmol of 1-NP and then taking the standard deviation of the 1-NP peak
2 areas and multiplying that value by 3. The detection limit for 1-NP was 0.32 fmol/injection. This
3 value is two orders of magnitude lower than the values obtained with recent HPLC methods with
4 on-line reduction and fluorescence detection [21, 22], the LC-atmospheric pressure chemical
5 ionization (APCI)-MS method [23] and HPLC with electrochemical detection [24], and comparable
6 to the values obtained with the GC-MS method with negative ion chemical ionization [25] and the
7 HPLC-tandem MS method with on-line reduction [14]. The achieved detection limit in this study
8 may be partly due to the recent improvement of fluorescence detector itself. The quantification limit
9 taken as the lowest concentration in the linear range was 4.6 fmol/m³.

10 The precision and accuracy of 1-NP determination in airborne particulate matter with the
11 present HPLC system were examined by adding two different known amounts of 1-NP to a sample
12 extract. The results are summarized in Table 1. The relative standard deviations (RSD, %) of the
13 intra- and inter-day precision study were in the range of 0.4 – 9.7% for the sample extract spiked at
14 the two concentrations. The accuracy values (%) of the intra- and inter-day study were in the range
15 of 94 – 98%. These values indicate that the proposed method is satisfactory for determining 1-NP in
16 airborne particulates.

17 The proposed HPLC method was used to determine the 1-NP concentrations in PM_{2.5} samples
18 collected by low volume portable air samplers at one indoor site and one outdoor site (see the
19 experimental section) that were thought to be surrounded by few pollutant sources. As mentioned
20 above, PM_{2.5} as an air quality indicator has been well justified from a health risk viewpoint and
21 primarily originates from combustion sources such as diesel exhaust. A representative
22 chromatogram of the extract from an indoor PM_{2.5} sample is shown in Fig. 3 (B). The atmospheric
23 1-NP mean concentrations of the indoor (n = 4) and outdoor air (n = 3) samples were 5.9 (range:
24 4.2-6.3) and 11.5 (range: 5.2-19.0) fmol/m³, respectively. As we expected, the 1-NP concentrations
25 at the sites were low. In fact, they were in the low fmol/m³ range and were lower than the
26 atmospheric 1-NP concentrations in work environments associated with diesel exhaust [9] and in an
27 outdoor rural area in Kanazawa city [26]. The proposed method has enough sensitivity and
28 precision to evaluate the atmospheric 1-NP levels in residential microenvironments and is
29 applicable for the personal exposure to 1-NP.

30

31 **4. Conclusions**

1 A simple and sensitive HPLC method for determining the concentration of 1-NP in airborne
2 particulate matter was developed using a deuterated internal standard with fluorescence detection.
3 The column switching system enables us to analyze 1-NP in a real sample treated with only a
4 simple solvent extraction without any interfering peaks, and the use of the deuterated internal
5 standard for fluorescence detection gave the assay high precision. The proposed method is
6 promising for the determination of trace levels of 1-NP in PM_{2.5} samples and is thus suitable for use
7 with low volume portable air samplers, which makes it possible to obtain accurate measurements
8 for personal daily exposure.

9

10 **Acknowledgements**

11

12 This study was partly supported by the Industrial Technology Research Grant Program in 2005
13 from New Energy and Industrial Technology Development Organization (NEDO) of Japan (ID:
14 05A21705a), by a Grant-in-Aid for Cancer Research (20-6) from the Ministry of Health, Labour
15 and Welfare, and by a Grant-in-Aid for Scientific Research from the Ministry of Education, Culture,
16 Sports, Science and Technology, Japan.

1 **References**

- 2
- 3 [1] IPCS INCHEM, Environmental Health Criteria (EHC), No. 171, WHO, Geneva, 1996.
- 4 [2] J. Arey, B. Zielinska, R. Atkinson, A.M. Winer, T. Ramdahl, J.N. Pitts, *Atmos. Environ.* 20
5 (1986) 2339.
- 6 [3] K.Hayakawa, Y. Kawaguchi, T. Murahashi, M. Miyazaki, *Mutat. Res.* 348 (1995) 57.
- 7 [4] IARC Monographs on Evaluation of Carcinogenic Risk to Humans, IARC, Lyon, 1989.
- 8 [5] P.T.J. Scheepers, M.H.J. Martens, D.D.Velders, P. Fijneman, M. van Kerkhoven, J. Noordhoek,
9 R.P. Bos, *Environ. Mol. Mutagen.* 25 (1995) 134.
- 10 [6] H.A. Bamford, D.Z. Bezabeh, S. Schantz, S.A. Wise, J.E. Baker, *Chemosphere* 50 (2003) 575.
- 11 [7] C.A. Pope, M.J. Thun, M.M. Namboodiri, D.W. Dockery, J.S. Evans, F.E. Speizer, C.W. Heath,
12 *Am. J. Respir. Crit. Care Med.* 151 (1995) 669.
- 13 [8] P.T.J. Scheepes, D. Coggon, L.E. Knudsen, R. Anzion, H. Autrup, S. Bogovski, R. P. Bos, D.
14 Dahmann, P. Farmer, E. A. Martin, V. Micka, V. Muzyka, H.G. Neumann, J. Poole, A.
15 Schmidt-Ott, F. Seiler, J. Volf, I. Zwirner-Baier, *Toxicol. Lett.* 134 (2002) 305.
- 16 [9] P.T.J. Scheepers, V. Muzyka, R. Anzion, D. Dahmann, J. Poole, R. P. Bos, *Ann. Occup. Hyg.* 47
17 (2003) 379.
- 18 [10] P.T.J. Scheepers, D.D.Velders, M.H.J. Martens, J. Noordhoek, R.P. Bos, *J. Chromatogr. A* 677
19 (1994) 107.
- 20 [11] J. Cvaöcka, J. Barek, A.G. Fogg, J.C. Moreira, J. Zima, *Analyst* 123 (1998) 9R.
- 21 [12] K. Hayakawa, K. Noji, N. Tang, A. Toriba, R. Kizu, S. Sakai, Y. Matsumoto, *Anal. Chim. Acta*
22 445 (2001) 205.
- 23 [13] N. Tang, A. Toriba, R. Kizu, K. Hayakawa, *Anal. Sci.*, 19 (2003) 249.
- 24 [14] J.P. Miller-Schulze, M. Paulsen, A. Toriba, K. Hayakawa, C.D. Simpson, *J. Chromatogr. A*
25 1167 (2007) 154.
- 26 [15] J.P. Miller-Schulze, M. Paulsen, A. Toriba, N. Tang, K. Hayakawa, K. Tamura, L. Dong, X.
27 Zhang, C.D. Simpson, *Environ. Sci. Technol.*, in press.
- 28 [16] S.B. Tejada, R.B. Zweidinger, J. E. Sigsby, Jr., *Anal. Chem.* 58 (1986) 1827.
- 29 [17] S.A. Wise, L.C. Sander, W.E. May, *J. Chromatogr.* 642 (1993) 329.
- 30 [18] A. Toriba, Y. Kuramae, T. Chetiyankornkul, R. Kizu, T. Makino, H. Nakazawa, K. Hayakawa,
31 *Biomed. Chromatogr.* 17 (2003) 126.

- 1 [19] T. Chetiyankornkul, A. Toriba, R. Kizu, T. Makino, H. Nakazawa, K. Hayakawa, J.
2 Chromatogr. A 961 (2002) 107.
- 3 [20] A. Toriba, T. Chetiyankornkul, R. Kizu, K. Hayakawa, Analyst 128 (2003) 605.
- 4 [21] C.-T. Kuo, H.-W. Chen, S.-T. Lin, Anal. Chim. Acta 482 (2003) 219.
- 5 [22] C. Schauer, R. Niessner, U. Pöschl, Anal. Bioanal. Chem. 378 (2004) 725.
- 6 [23] H. Moriwaki, K. Funasaka, M. Uebori, Anal. Sci. 16 (2000) 1247.
- 7 [24] C.-T. Kuo, H.-W. Chen, J. Chromatogr. A 897 (2000) 393.
- 8 [25] A. Albinet, E. Leoz-Garziandia, H. Budzinski, E. Villenave, J. Chromatogr. A 1121 (2006) 106.
- 9 [26] N. Tang, M. Tabata, V.F. Mishukov, V. Sergineko, A. Toriba, R. Kizu, K. Hayakawa, J. Health
10 Sci. 48 (2002) 30.

1 **Figure Legends**

2

3 Fig. 1. Schematic diagram of the proposed HPLC system for the determination of 1-NP.

4 Fig. 2. Schematic diagram of the analytical procedures.

5 Fig. 3. Representative HPLC chromatograms of a standard solution (A) corresponding to 5 fmol
6 1-NP / injection and a PM_{2.5} sample of the indoor air (B).

Table 1. Precision^a and accuracy^b in the determination of 1-NP in airborne particulate matter

	Intra-day assay (n=4)			Inter-day assay (n=4)		
Added amounts (pM)	0	25	250	0	25	250
Found ± uncertainty ^c (pM)	8.5 ± 0.3	31.9 ± 2.2	248 ± 2	7.9 ± 1.2	32.0 ± 2.6	252 ± 6
RSD (%)	2.5	4.3	0.4	9.7	5.1	1.6
Accuracy (%)	-	94	96	-	97	98

^a Precision is expressed as the percentage of relative standard deviation (RSD, %).

^b Accuracy is expressed as the percentage of accuracy [(mean observed concentration/ spiked concentration) × 100].

^c Uncertainty is 95% confidence level calculated using the equation (Student's $t \times SD/\sqrt{n}$)

Figure 1
Ohno et al.

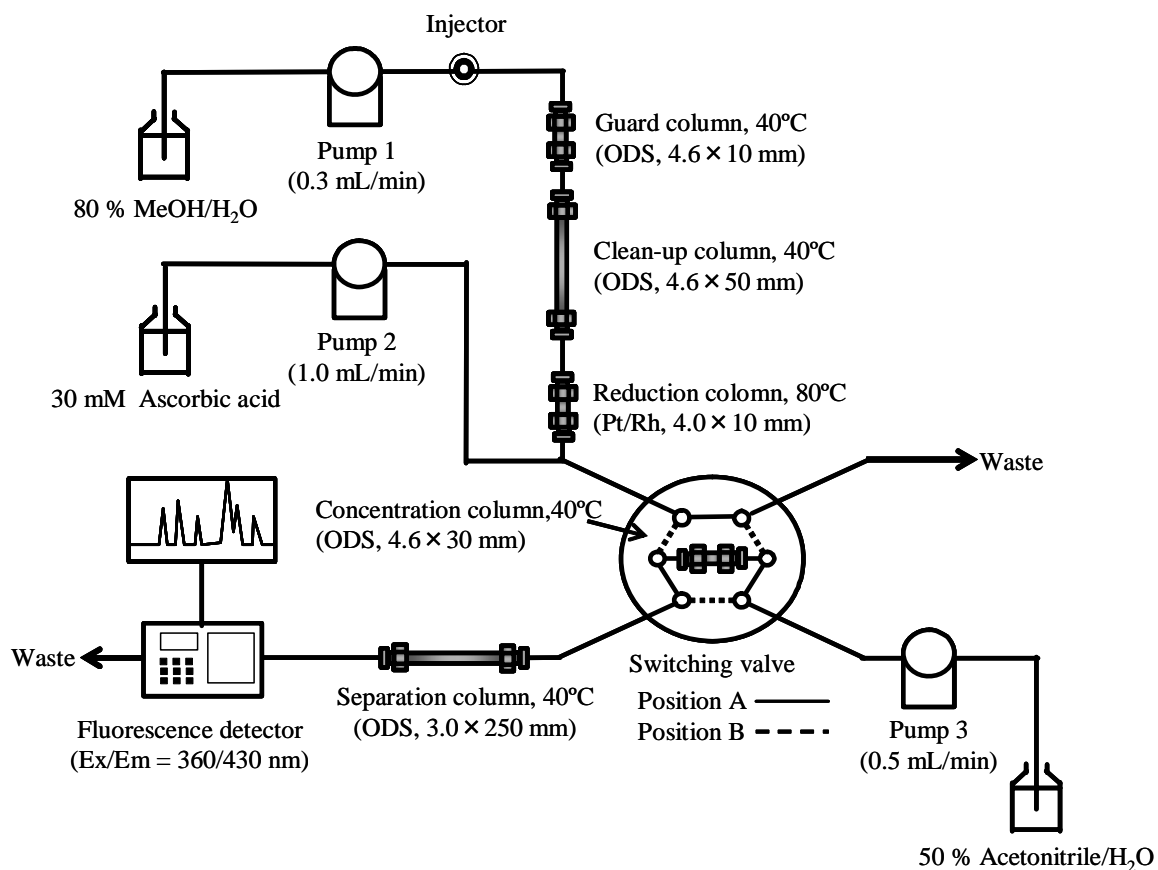

1
2
3 1. Sample extraction

4 Filter sample (particles < 2.5 μm ($\text{PM}_{2.5}$) on a 20 mm Emfab filter)

5 + Internal standards (1-NP- d_9)
6 + DMSO (20 μL)
7 Extracted with benzene/ethanol (2 mL) \times 2
8 Evaporated
9 + Acetonitrile (80 μL)

Sample solution (ca. 100 μL)

10 2. HPLC analysis (time events for the column-switching procedure)

11 a) Injection step (0 min, position A):

12 20 μL of the sample solution is injected.

13 b) Clean-up and reduction step (0-12 min, position A):

14 The analytes were separated on the clean-up column from interfering substances
15 and then reduced to the corresponding amino-derivatives by the reduction
16 column.

17 c) Trapping step (12-16 min, position B):

18 The reduced analytes were trapped on the concentration column with decreasing
19 the content of methanol in the eluate.

20 d) Detection step (16-40 min, position A):

21 The enriched substances were eluted and separated on the separation column.
22
23
24
25
26
27
28
29
30
31

Figure 3
Ohno et al.

