

An experimental Study on Sediment Transport Processes for Reconstruction of Past Hydrological Environment

メタデータ	言語: eng 出版者: 公開日: 2017-10-05 キーワード (Ja): キーワード (En): 作成者: メールアドレス: 所属:
URL	http://hdl.handle.net/2297/6502

An Experimental Study on Sediment Transport Processes for Reconstruction of Past Hydrological Environment

Shinya OCHIAI^a and Kenji Kashiwaya^a

(a) Institute of Nature and Environmental Technology, Kanazawa University, Kakuma-machi, Kanazawa, Ishikawa, 920-1192, JAPAN

A lake-catchment system is thought to be a recorder of climato-hydrological environment, such as precipitational intensity, water discharge and tractive force in the catchments. Information about past hydrological environment is useful for estimating the future hydrological change related to climatic change such as global warming. Erodible material in catchments is eroded and transported to downstream lake by water flow in this system. Sedimentation rate and grain size of lake sediment may reflect climato-hydrological fluctuation because sediment discharge and grain size from the catchment are controlled by hydrological conditions. For quantitative reconstruction of past hydrological environment, it is necessary to clarify how to record hydrological environments (sediment transport processes) in lake sediments.

In the first step, we will discuss sediment transport processes in a short river segment which has constant and uniform conditions with respect to flow direction. Numerical model and artificial channel experiment are performed to clarify the relationship between sediment discharge and sediment influx to river and hydrological conditions.

To simulate sediment transport in river segment, simplified two-dimensional model was introduced. Flow conditions such as flow velocity, slope and water depth were assumed to be constant and uniform with respect to flow direction. Sediment discharge in this river segment was calculated with advection-diffusion equation. Controlled hydrological conditions in this model are water discharge, channel slope. Calculated results suggest that sediment discharge of river may be controlled by sediment upward flux from riverbed. This result suggests existence of maximum sediment discharge.

A transparent plastic channel (6.5 m length and 0.15 m width) has been made for artificial channel experiment (Figure 1). A water pump is used for supplying water to the upstream tank. Water flows through the channel and falls to downstream tank. We can control sediment flux at the upstream end with a sand feeder. Water discharge is controlled with water valve. The slope of channel is variable with three jacks supporting the channel. We employ some sediment concentration measurements; direct water sampling and photometrical recording with laser sensor (Figure 2). Photometrical recording is based on measurement of light transmittance through turbid water. Sediment concentration for the turbid water is estimated with the light transmittance data and the calibration curve previously measured. This method has the advantage of non-contact and continuous measurement. The ultrasonic sensor is used to measure water level change which is important parameter for estimation of tractive force. Present issue is how to control and measure conditions. In this symposium, we report technical issue of experiment and the present results, and discuss sediment transport processes on the basis of present results.

^a Electronic Address: ochiai@nihonkai.kanazawa-u.ac.jp

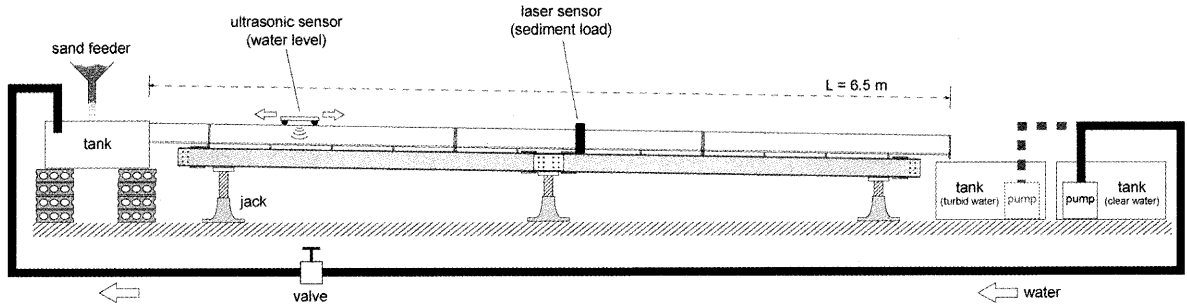

Figure 1 Schematic illustration of the channel experiment.

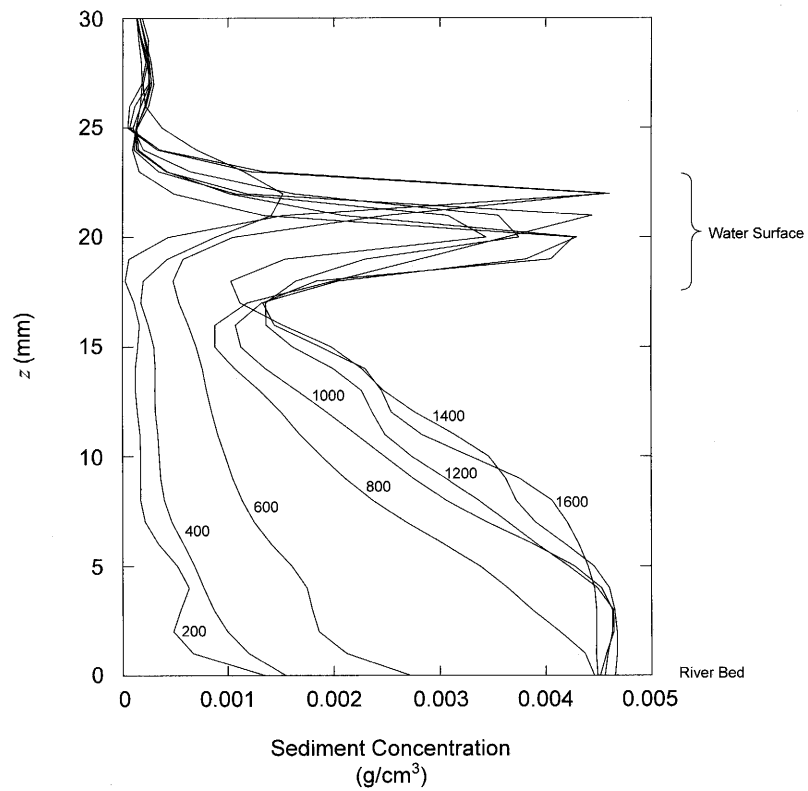

Figure 2 Vertical profiles of sediment concentration measured with laser sensor. Y-axis indicates sediment concentration and X-axis indicates height from the river bed. Small figures indicate time from the start of experiment. High concentration at about $z = 20$ (mm) results from diffused reflection at the water surface.