

Mixture of Kosa (Asian dust) and bioaerosols detected in the atmosphere over the Kosa particles source regions with balloon-borne measurements: possibility of long-range transport

メタデータ	言語: eng 出版者: 公開日: 2017-10-06 キーワード (Ja): キーワード (En): 作成者: メールアドレス: 所属:
URL	https://doi.org/10.24517/00040004

This work is licensed under a Creative Commons Attribution-NonCommercial-ShareAlike 3.0 International License.



Mixture of Kosa (Asian dust) and bioaerosols detected in the atmosphere over the Kosa particles source regions with balloon-borne measurements: possibility of long-range transport

Y. Iwasaka · G.-Y. Shi · M. Yamada · F. Kobayashi ·
M. Kakikawa · T. Maki · T. Naganuma · B. Chen ·
Y. Tobo · C. S. Hong

Received: 15 September 2008 / Accepted: 9 February 2009 / Published online: 13 March 2009
© The Author(s) 2009. This article is published with open access at Springerlink.com

Abstract Long-range transport of atmospheric microbiota with Asian dust (Kosa) particles is of great concern in Northeast Asia in view of the health effect of Kosa particles on human being, disturbance of ecosystems caused through invasion of new microbe, contribution of microorganisms to biogeochemical cycle on global/regional scales, and

others. Information on atmospheric microbes over the desert areas has been desired for a long time. Detection of atmospheric microbiota on the desert regions, on the base of balloon-borne measurements, has been made at Dunhuang, China (40°00' N, 94°30' E; east end of Taklamakan desert) in the summer of 2007. The measurements showed that microbiota mixed internally with Kosa particles were frequently floating from the ground to about 2-km heights (above sea level), and possible long-range transport of atmospheric microbiota with dust particles taking local circulations is strongly suggested, causing active mixing of atmospheric dust over the Taklamakan desert from the ground to the free troposphere where westerly jet dominates (Iwasaka et al. in *J Geophys Res* 108:8652, 2003a, *J Geophys Res* 108:8644, b). The concentration of the mixed particles of Kosa and microbiota having a size larger than about 1 μm in diameter is estimated to be about 1 particle/ cm^3 at those heights on the basis of measurements of particle concentration with an optical particle counter and analysis of particles having fluorescence light due to dye of DAPI (4'-6-diamidino-2 phenylindole) with an epifluorescence microscope. The mixing situation of microbiota and Kosa particles is the important factor controlling atmospheric lifetime of floating microbiota, since the mixing state certainly can protect microbiota from stressful environments [dryness, solar ultraviolet (UV) radiation, low temperature] in the atmosphere, and therefore, it is useful to discuss the data of the first description of microbiota in the atmosphere on the Taklamakan desert.

Presented at the 5th International Workshop on Sandstorms and Associated Dustfall, Urumqi, China, 22 May 2008

Y. Iwasaka (✉) · Y. Tobo · C. S. Hong
Frontier Science Organization, Kanazawa University,
Kanazawa, Japan
e-mail: kosa@staff.kanazawa-u.ac.jp

G.-Y. Shi · B. Chen
Institute of Atmospheric Physics, Chinese Academy of Science,
Beijing, China

M. Yamada
Faculty of Environmental and Symbiotic Sciences,
Prefectural University of Kumamoto,
Kumamoto, Japan

F. Kobayashi · T. Maki
Graduate School of Natural Science and Technology,
Kanazawa University,
Kanazawa, Japan

M. Kakikawa
Institute of Nature and Environmental Technology,
Kanazawa University,
Kanazawa, Japan

T. Naganuma
Graduate School of Biosphere Science, Hiroshima University,
Higashi-Hiroshima, Japan

Keywords Dust particle · Microbiota (microorganism) ·
Desert areas in China · Balloon-borne measurement ·
Mixture of Kosa microbiota

Introduction

Biogenic aerosol particles (bioaerosols) range in size from millimeters down to tens of nanometers, and like pollen, bacteria, spores, viruses, plant, and animal fragments, these have been believed, from the view point of aerodynamics, to be easily transported long range in the atmosphere through various scale air dynamical processes and to be ubiquitous in the Earth atmosphere, especially in the lower atmosphere. Consequently, those particles are suggested to possibly influence environment, climate, public health, and others in regional and or global scales (Griffin et al. 2001; Prospero et al. 2005; Ariya and Amyot 2004; Lohmann and Feichter 2005; Keene and Galloway 1988; Kanakidou et al. 2005; Sun and Ariya 2006; Fuzzi et al. 2006; Elbert et al. 2007; Möhler et al. 2007). Recent studies also emphasize the role of bacteria present in polar or mountain environments and suggest the importance of studies on the atmospheric long-range transport of microbiota (Skidmore et al. 2000; Toom-Aaunty and Barrie 2002; Amato et al. 2007; Zhang et al. 2007).

There have been, however, only few observations which have valuable information to help understand processes in long-range transport of microorganisms due to technical difficulty to directly observe microorganisms in the atmosphere, especially in the free atmosphere where long-range transport of atmospheric constituents is very active. Griffin et al. (2001), Kellogg and Griffin (2006) and others, from the summary of measurements which were made on the basis of the ground-based sampling of particulate during dust episodes and of the analysis of satellite data, show the possibility that biogenic aerosols have been frequently found on other types of aerosols such as dust, sea spray, and others, which were transported long range in the atmosphere. Their conclusion is very suggestive, but there still remain some problems to be solved because most of collections of atmospheric constituents were made near the ground where local contaminations are highly concentrated and analysis of samples have been made on the basis of bulk samplings. Single particle analysis, which is one of the most effective ways to see bioaerosol on dust and/or sea spray particles, has not been made yet.

It is interesting and important to observe, from view of long-range transport of atmospheric bioaerosols in the northeast Asian regions, whether the Kosa (Asian dust) particles having microorganisms on their surface (internal mixture of Kosa and microorganisms) are floating in the atmosphere over the dust source regions or not, considering that dominant westerly wind strongly affect long-range transport of dust particles (Iwasaka et al. 1984, 2003a).

For microbial cells floating in the free atmosphere where long-range transport of atmospheric constituents is very frequently observed, their long-range travel has been believed very stressful work, since the free troposphere has, comparing

with the boundary layer atmosphere, lower humidity, stronger solar ultraviolet radiation, and more active photochemical reactions. State of internal mixture of microbiota and dust particles seems to protect microbiota from these stresses during long-range travel in the atmosphere.

It is well known that Kosa (Asian dust) particles are important constituents controlling climate and geochemical cycles of minerals and pollutants in the Asia Pacific regions (e.g., Iwasaka et al. 1988; Heubert et al. 2003), and long-range transport of Kosa in the free troposphere can largely contribute to them (e.g. Sokolik et al. 2001; Uno et al. 2001; Mikami et al. 2006). Additionally, if Kosa particles mix with microorganisms, some of those particles can act as good heterogeneous nuclei and activate cloud formation and precipitation in those regions (e.g., Maki et al. 1978; Möhler et al. 2007).

We made campaign measurements of Kosa and microbiota in the atmosphere at Dunhuang, China in 2007 with balloon-borne particle sampler to understand the mixing features of Kosa and microbiota in the atmosphere over the Taklamakan desert. As suggested by Sun et al. (2001), Iwasaka et al. (2003a), and Uno et al. (2004), Taklamakan desert has large potential to inject dust particulate into the atmosphere and to transport those particle long range by westerly wind, even in the time without severe low pressure system, through active local circulations formed on the slope of the mountains surrounding the Tarim basin.

Therefore, Dunhuang (40°00' N, 94°30' E), which is located on the east end of the Tarimu basin (Taklamakan desert), is an effective site to obtain information of the mixing features of Kosa with microorganisms flowing out from the Taklamakan desert.

In this paper, we present meteorological conditions during the campaign measurement in order to show that collection of Kosa and microbiota was made under relatively calm conditions and not extremely disturbed conditions. Measured aerosol concentrations show good agreement with the previous measurements (Iwasaka et al. 2003a, b, Kim et al. 2004), suggesting that particle content was in background level in Dunhuang, China. From combining those total particle concentrations and the relative concentration of internally mixed particles of Kosa and microorganism, we roughly estimated concentration of internal mixture of Kosa and bioaerosol in the atmosphere. Possibility of long-range transport of bioaerosols is discussed combining the results obtained during the campaign measurements at Dunhuang and the previous Kosa measurements there.

Observation

Balloon-borne measurements were made at Dunhuang (40° 00' N, 94°30' E), China (Fig. 1), which is on the east side of

Fig. 1 Observation was made at Dunhuang, China. Particulate originated in Taklamakan desert is frequently transported long range through combination of westerly wind and local circulations

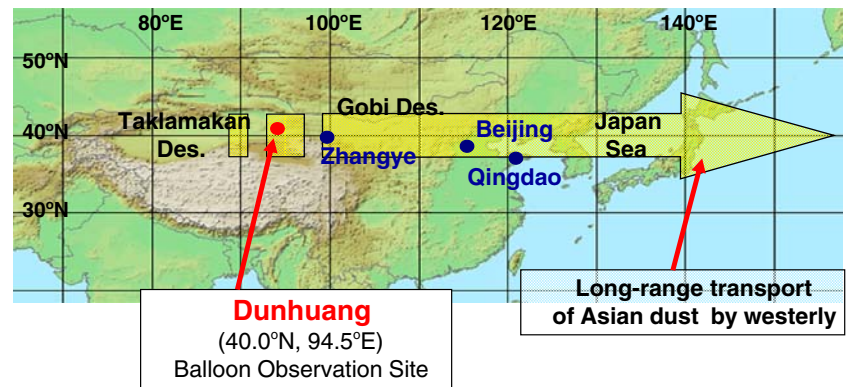

the Tarim Basin (Taklamakan desert). The tethered balloon used here has a volume of about 15 m³ and potential payload of 10 kg at ceiling level of 4 km altitude. As suggested by Uno et al. (2004) and Sun et al. (2001), geographical features of the Tarim basin largely contributes to the formation of active local circulation systems which are effectively mixing atmospheric constituents up to the heights of the summit of mountains surrounding the Tarim basin (about 5 km), and westerly wind existing above the summit of mountains can easily transport those constituents long range. Iwasaka et al. (2003a) suggested, on the basis the balloon-borne and lidar measurements made at Dunhuang, China, that westerly wind appeared clearly above about 5 km even in the summer season and that dust-like particulates were well mixed from near the ground to about 5 km due to active local circulations in the Taklamakan desert and after then transported long range by westerly wind. Therefore, it is possible, if Kosa particles containing microorganisms are detected in the lower atmosphere at Taklamakan desert region, to consider that the particulates including microorganisms also are transported to active local circulation to the height of the summit of mountains and transported out from the Taklamakan desert areas long range by westerly wind.

As shown in the composition of the balloon train, aerosol particle size and concentration (optical particle counter, OPC), atmospheric temperatures (thermo couple), and relative humidity (polymer film sensor, electric capacitance type) are simultaneously observed during the collection of aerosol particles from near the ground to 2,300 m (above sea level; Fig. 2).

In Table 1, observational items and weather during observational periods are summarized. Table 2 summarized specifications of the optical particle counter, thermometer, and hygrometer mounted on the balloon. Heights of the balloon were monitored by global positioning system mounted on the balloon, and the values measured by those were transferred to the operating room on the ground by radio. Block diagram of particle collector is shown in Fig. 3, and the particle collectors were controlled remotely

using radio wave transmitter. We observed mixing features of the particles collected in the atmosphere with a laser fluorescence microscope and counted the number of mixture type particles with Kosa and microorganism.

Particle concentration and mixture of Kosa and microorganism

The changes in temperature and humidity as altitude change during the particle collection are shown in Fig. 4. Concentration and size of atmospheric aerosols monitored during the collection were compared with the atmospheric temperature and humidity in Fig. 4.

Dunhuang area, during the observations, was affected by weak low pressure, but weather was relatively calm and no severe dust storms were observed there. Relative humidity was a little higher (70–85 %) at around 1000 (Beijing standard time), August 17 (third flight, panel c in figure) and extremely high (about 95%) in heights of about 1.9 km around 1315 (Beijing standard time) August 17 (fourth

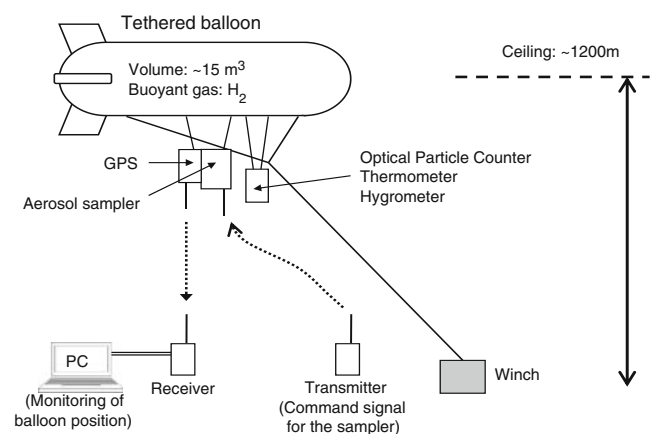

Fig. 2 Composition of balloon train. Tethered balloon was used to collect dust and micro-bioaerosol particles from the ground to heights of about 1,200 m (from 1,100 to 2,300 m above sea level). Particle number concentration and size, atmospheric temperature, and humidity were simultaneously monitored

Table 1 Weather conditions

	Weather and cloudiness	Wind direction and speed	Items observed	Comments
Aug 16 11:27–12:11 Fig. 4a	Cloudy Cloud type: Sc	E 7–8 m/s	OPC Bioaerosol collector Temperature Humidity Balloon height	Time is based on the Beijing standard time. Wind direction and speed was measured at ceiling level (see Figs. 2 and 4)
Aug 16 13:29–13:55 Fig. 4b	Cloudy Cloud type: Sc	SE-E 7–8 m/s	OPC Bioaerosol collector Temperature Humidity Balloon height	No report
Aug 17 10:09–10:32 Fig. 4c	Cloudy Rain	E 5–6 m/s	OPC Bioaerosol Collector Temperature Humidity Balloon height	No report
Aug 17 12:53–13:17 Fig. 4d	Change Cloudy to fine	No measurements	OPC Bioaerosol collector Temperature Humidity Balloon height	Cloudiness was smaller than 8/10
Aug 17 18:07–18:28 Fig. 4e	Fine	E 5–6 m/s	OPC Bioaerosol Collector Temperature Humidity Balloon height	Cloudiness was smaller than 2/10
Aug 17 19:59–20:25 Fig. 4f	Fine	E 7 m/s	OPC Bioaerosol collector Temperature Humidity Balloon height	Cloudiness was smaller than 0/10

flight, panel d in figure). Without those periods, relative humidity was in about 50–60% in August 17 and 30–20% in August 16. Previous measurements made at Dunhuang in the summer of 2002, 2003, and 2004 showed relatively high humidity several times when low pressure appeared (Iwasaka et al. 2008). Therefore, it is suggested that the

Table 2 Instruments mounted balloon

Instruments	Typical specifications	Type
Optical particle counter	Sizing is made, Diameter at 0.3, 0.5, 0.7, 1.2, and 5.0 μm	KR-12A, Rion Co. Ltd.
Hygrometer	Dynamic range, 20–96% RH Resolution, 1% RH	Weathecom EMPEX Co. Ltd.
Thermometer	Dynamic range, -30.0°C to 60.0°C Resolution, 0.1°C	Weathecom EMPEX Co. Ltd.

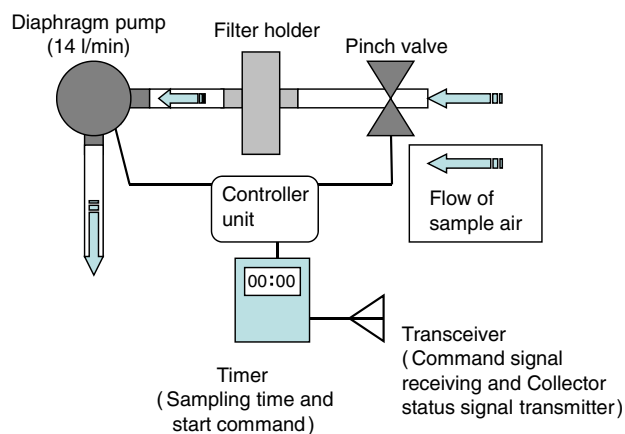

Fig. 3 Block diagram of particle collector mounted on the balloon. Command signals to operate controller (on and off of pump, setting of sampling time, and so on) was transmitted by radio

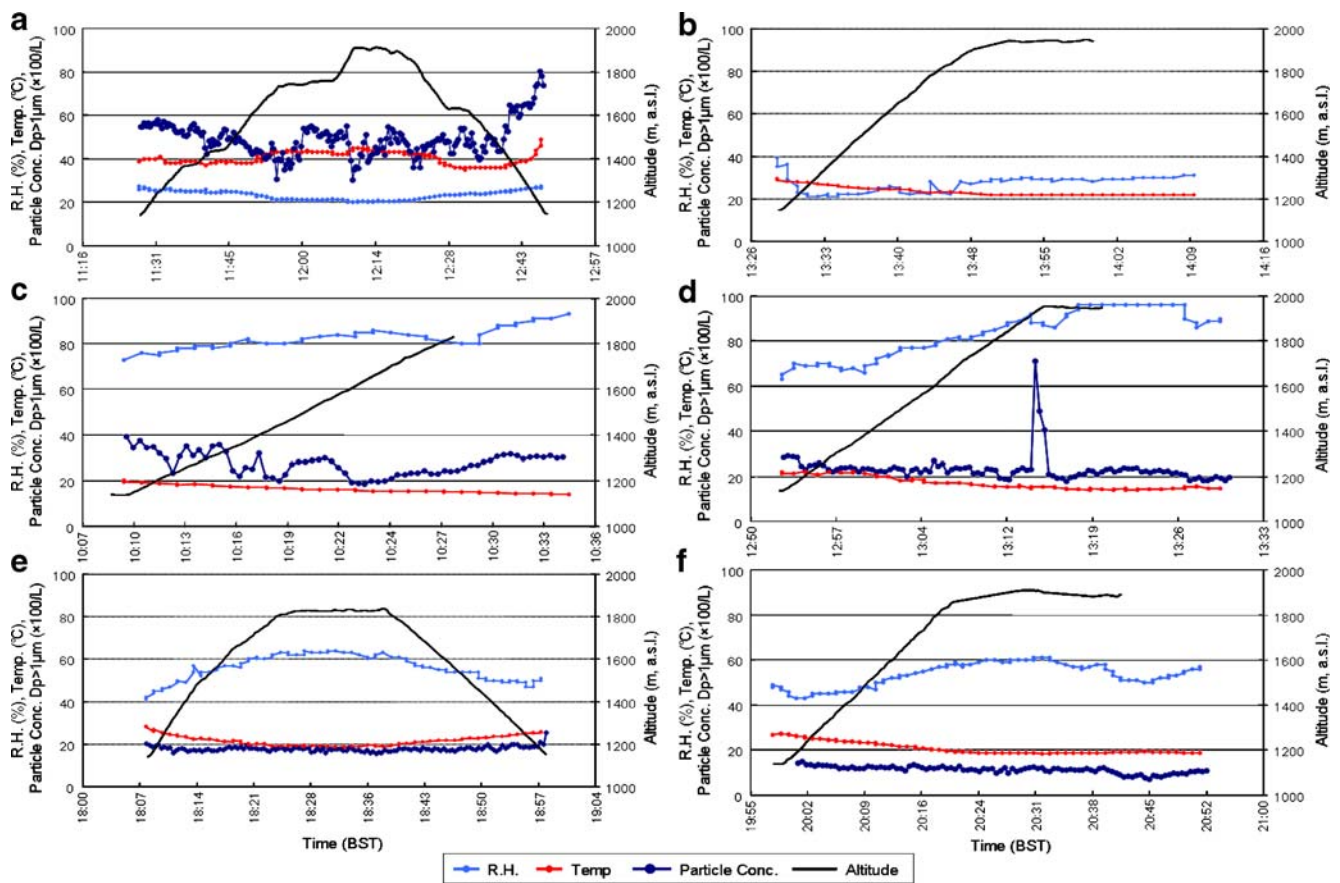

Fig. 4 Temporal and vertical changes in temperature, humidity, and concentration of aerosol particle in course mode range during the balloon-borne measurements. The panel index of a–f correspond to each balloon flight (see Table 1)

humidity of the observational periods are not unusual levels. However, the humidity found in 1.9 km altitudes in the fourth flight of August 17, 2007 is interestingly high considering that dryness seems to generally be a hard atmospheric condition to live for floating microorganisms in the atmosphere.

In the summer season, small-scale precipitation and cloud activities are observed several times in the desert areas, and in winter and spring, extremely dry air appears. Therefore, it is necessary to observe seasonal variations in concentrations and divergence of microbiota from view of mixing particle of Kosa microorganism particles in future in order to understand the effect of humidity on the activities of microorganisms.

Concentration of the particles with diameter, D , larger than $2.0 \mu\text{m}$ was in the range of $1.0\text{--}0.7$ particles/ cm^3 and concentration of the particle of $0.5 \leq D \leq 2.0 \mu\text{m}$ in the range of $10\text{--}3.0$ particles/ cm^3 . Comparing those with the particle number concentrations observed at Dunhuang in 2002 and 2003 (e.g., Iwasaka et al. 2008; Kim et al. 2004), the present values are the same levels with the previous ones, and it can be said that particle concentration measured here is in the background levels. Number–size distribution

patterns in Fig. 5, which are estimated from the measurements in Fig. 4, also have very similar features with the previous measurements, suggesting noticeable node in super micron size due to active mixing of super micron particles containing dust (Iwasaka et al. 2003a, b; Yamada et al. 2005). Electron microscopic observation of morphology and analysis of chemical elements of the particles collected in the atmosphere were made. Intensive measurements made by Iwasaka et al. (2003a, b) and Yamada et al. (2005) strongly suggested that the major components of super micron particles collected in the free troposphere and in the boundary layer atmosphere at Dunhuang, China were dust particles on the basis of the balloon-borne and ground-based lidar measurements. Figure 6 is a typical electron microgram of the particles obtained in the present balloon-borne measurements. The electron microscopic observations, as shown in Fig. 6, strongly reconfirm the previous suggestion that super micron particles were mostly composed of dust particles in the desert atmosphere.

It is, however, hardly possible to clarify whether the Kosa particles have a mixture state with microorganisms or are not only from the single particle observation with an electron microscope, possibly because most of the biogenic

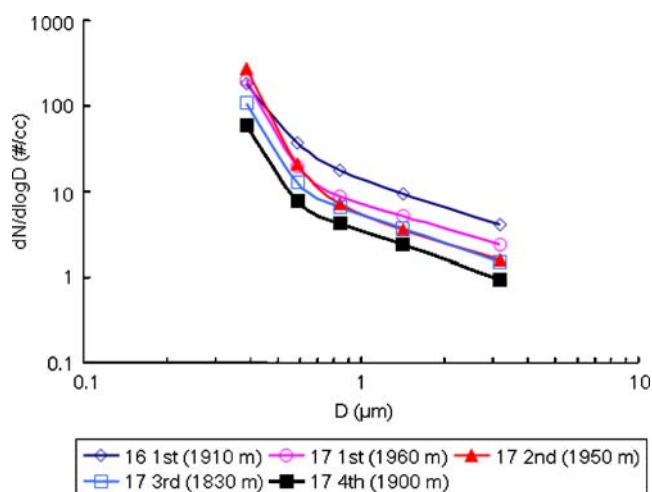
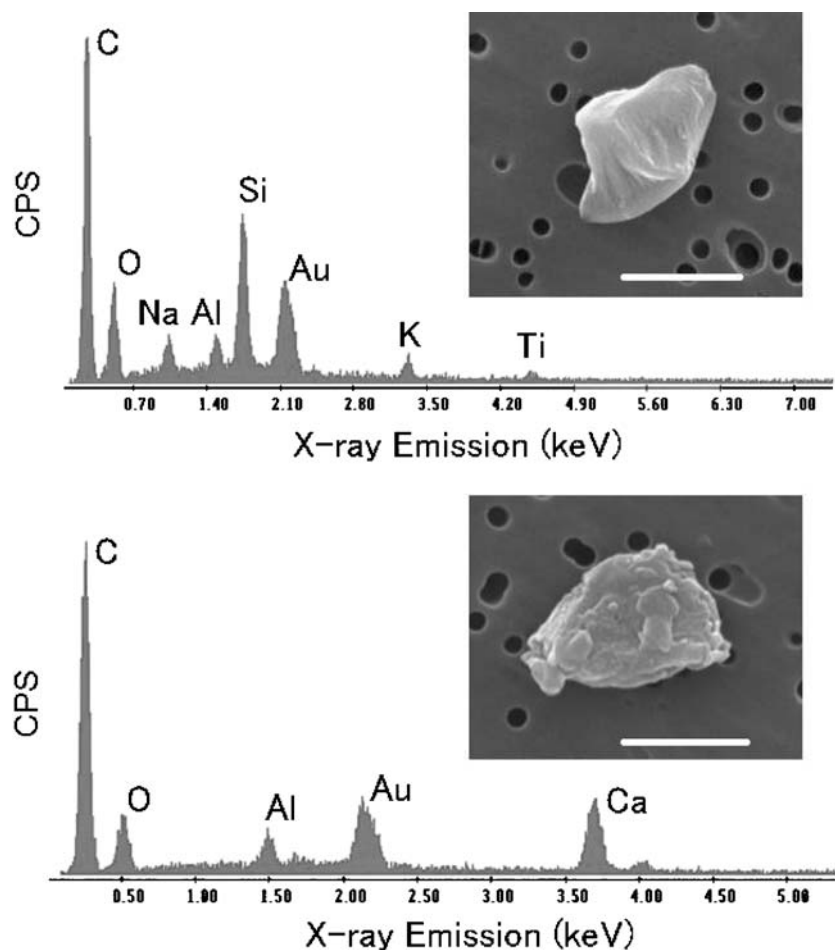

Fig. 5 Number and size distribution patterns of the particles measured at about 2-km heights above Dunhuang, China in August 2007. ‘16 1st’ means the first observation made in August 16, and *number in parenthesis* shows averaged height of ceiling. Observational times are shown in detail in Table 1

Fig. 6 Electron microgram of typical particles in super-micron particles collected in the atmosphere at Dunhuang, China in August, 2007 and EDX spectrum of the particles. The particle is suggested to be KOSA (dust) particles from the shapes and chemical elements contained. The *scale bar* means 5 μm



materials are highly volatile in general and those materials evaporate in the low pressure chamber of electron microscope, and high-energy electron beams sometimes largely destroy microbiota. Here, a fluorescence microscopic technique was used to observe the mixing state of dust materials and microorganisms. One milliliter of the filter washing solution of bioaerosol samples was fixed with a glutaraldehyde solution at a final concentration of 1%. The samples were stained with DAPI (4',6-diamino-2-phenylindole) at a final concentration of 0.5 $\mu\text{g}/\text{mL}$ for 25 min and filtered through 0.2- μm pore size membrane filters stained with Sudan Black (Porter and Feig 1980; Russell et al. 1974). The particulate matters on filters were observed using epifluorescence microscope (Olympus Co., Tokyo, Japan) under UV radiation to excite (Maki et al. 2008).

Typical example of the epifluorescence micrograph is shown in Fig. 7. The particle in Fig. 7 was collected about 800 m above the ground (about 2 km above sea level). The particle shapes have many similar points which have been frequently observed with the electron microscope by many investigators (Iwasaka et al. 1988; Okada and Kai 1995; Iwasaka et al. 2003b). Several Kosa particles showed one

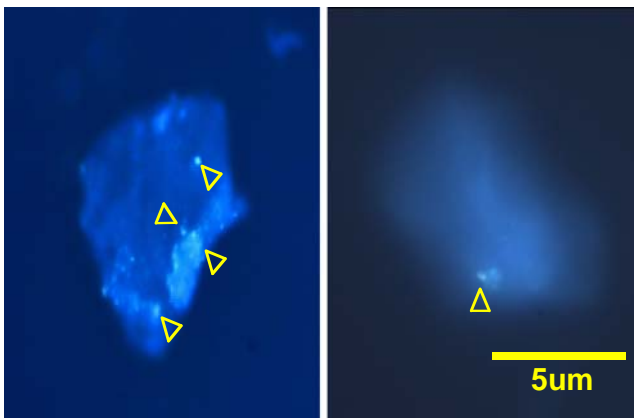

Fig. 7 Typical example of epifluorescence micrograph of the particles collected at about 800-m height above the ground (about 2 km above the sea level). Several KOSA particles show many fluorescence light spots on the surface (*left side* is typical example)

(or more) fluorescence light spot on their surface, suggesting that materials containing DNA originated in biogenic aerosols are coating the Kosa particle surface.

Discussion and conclusion

The particles shown Fig. 7 are the typical examples collected in the atmosphere (about 2 km above sea level) over Dunhuang, China, and one (or more) spot with strong fluorescence light is sometimes counted on the surface of each Kosa particle. This picture strongly suggests the existence of Kosa–bioaerosol mixtures in the desert atmosphere. Those mixtures are possibly transported long range through combination of local circulation and westerly wind above about 5 km, as described by Iwasaka et al. (2003a, 2008). However, there are many problems to be solved, as pointed below, in order to know the processes controlling the mixing state of Kosa–bioaerosols and discuss the possibility of their long-range journey:

1. relation between existence of microorganisms and chemical elements of Kosa,
2. relation between existence of microorganisms and Kosa particle surface and/or size,
3. biodiversity on microorganisms on the Kosa particles and/or size,
4. relation between the existence of microorganisms and roughness of Kosa particles surface, and
5. life or death of the microorganisms emitting fluorescence light on Kosa surface.

From only the present observations, it is hardly possible to discuss those points which are essential in clarifying physical and biological meanings concerning the distribution features of fluorescence light spots on the particle surface.

Quantitative information is important to discuss the environmental effect of long-range transport of microorganisms, such as concentration of internal mixtures of Kosa and microorganism, their size, ratio of the mixture to total Kosa particles, and their temporal and spatial variations.

According to the fluorescence micrograph analysis of the particles collected with balloon-borne sampler, about 10% of the Kosa particles had fluorescence light spots on the particle surface. The size range of the particles which can be observed with the epifluorescence micrometer is larger than about 4 μm owing to the resolution of fluorescence microscope, and it is impossible to identify the particles with D smaller than 4 μm . It is, however, possible to give a rough estimation of the number concentration of mixture state particles of Kosa and microbiota in the atmosphere combining the ratio obtained from the measurements with the epifluorescence micrometer and the number–size distributions measured with OPC simultaneously.

It is already suggested, on the basis of electron microscopic observation of the particles collected during intensive balloon-borne measurements, that most of the super micron particles in the atmosphere over the Taklamakan desert area are composed of Kosa particles (Iwasaka et al. 2003b; Yamada et al. 2005), and the present results strongly confirmed the suggestion as shown in Fig. 6. Therefore, the concentration of particles measured with the optical particle counter (Figs. 4 and 5) can be recognized as the concentration of Kosa particles in the super-micron-size range. The number concentration of the particles (mostly Kosa particles) with $D > 4 \mu\text{m}$ can be roughly estimated to be about 1 particle/ cm^3 from the extrapolations of the curves in Fig. 5. From the observation of Kosa particles with the epifluorescence micrometer, as described above, about 10% of Kosa with $D > 4 \mu\text{m}$ had fluorescence lights on its surface. Consequently, it can be suggested that the concentration of Kosa–microbiota mixture particles is about 0.1 particle/ cm^3 ($10\% \times 1 \text{ particles}/\text{cm}^3$) in the particle size range, $D > 4 \mu\text{m}$ in the lower atmosphere over Dunhuang, China.

Additionally, if we assume that the ratio of Kosa–microbiota mixture in the super-micron-size range ($D > 1 \mu\text{m}$) also is 10%, the same with the particles with $D > 4 \mu\text{m}$, the concentration of Kosa–microbiota mixture is estimated to be about 1 particle/ cm^3 in the atmosphere over Dunhuang, China, taking the results shown in Fig. 5 into consideration. This value is a little larger compared to the observations of dust source regions summarized by Kellogg and Griffin (2006), but atmospheric conditions of sampling sites largely differ from each other, and additionally, analytical procedures also differ. The values in their review are based on the culture and isolate of samples. The kinds of microbiota which we can culture are strongly limited, and the number

concentration estimated from the way depending on culturing shows values largely smaller than the real values. The procedure used here is originally culture-independent. Therefore, it is reasonably expected that the present measurements show relatively higher concentration compared with previous values. The most important point, however, is that the possibility of relatively high concentration of dust–microorganism mixture particles is qualitatively suggested from the present field observations and the comparison of the information obtained with various methods to understand the concentration of microbiota in the atmosphere.

According to the recent work of Jaenicke (2005), about 25% of particulate suspended in air (by mass or number), which are suggested, on the basis of numerous observations, mainly via staining methods to distinguish individual protein-containing particles from others, are primary biological aerosol particles. Their suggestion showed very similar mixing ratio with the value of 10% obtained here. However, atmospheric conditions seem to be largely different in both measurements; the present measurements were made in a desert atmosphere and their observations were based on a summary of observations of various types of airs. Additionally, identifying procedures are largely different from each other. The present research is based on the observations during highly limited observational times, and therefore, it is strongly desired to continue the long-term observation at various seasons and to expand spatial observation scale including the free atmosphere in order to clarify the features of Kosa–bioaerosol mixture in the source areas of dust particles.

The concentration of dust particles, according to the balloon-borne and aircraft-borne measurements, decreased to 1/10–1/100 averagely during long-range transport from the Taklamakan desert to Japan islands in calm atmospheric conditions (Iwasaka et al., 2008). Assuming the same dilution rate for the mixture of Kosa and microbiota, it is suggested that concentration of mixture particles of Kosa and microbiota is estimated to be about 0.01–0.001 particles/cm³ in super micron size in the free troposphere over Japan islands. As described in “Introduction,” some microorganisms have been suggested as active ice nuclei and/or condensation nuclei, and those particles are possibly scavenged through cloud formation and precipitation during their long-range transport when they meet cold and high humidity air. However, the contribution of those particles’ behavior to changes in the concentration of bioaerosols (or Kosa–bioaerosol mixtures) is obscure, since it is hardly possible to estimate the ratio of the bioaerosols having potential of ice nuclei to concentration of total bioaerosols. At least, it is possible to point out that the estimated values can decrease if scavenging processes are effective and larger than the concentrations estimated based on the measurements including culturing bioaerosols, as pointed

out before. The air transported by westerly wind is frequently observed over Japan, but air originated in marine is also frequently observed especially in the summer season. The concentrations of the mixture estimated here become much lower during the time when marine air covers Japan islands.

There have been few observations made in Japan to know the concentration of Kosa–microorganism mixture. However, some studies suggest the possibility of long-range transport of microorganisms from China continent to Japan islands. Hua et al. (2007) suggested the possibility of long-range transport of microorganism considering the highly similar genetic identities of dust sample collected at Hiroshima, Japan and Dunhuang, China. Maki et al. (2008) and Kakikawa et al. (2008), comparing their results with measurements at Korea and Taiwan (Wu et al., 2004; Yeo and Kim 2002), suggested long-range transport of microorganisms (members of the genus *Bacillus*, *Rhodococcus*, *Staphylococcus*, and others). Kobayashi et al. (2008), on the basis of balloon-borne particulate collection made at Kanazawa, Japan, pointed out that *Bacillus cereus* and *Pycnoporus* sp. were identified not only in the air above Dunhuang, China but also the air mass transported from the China continent to Kanazawa, Japan (2008). Those investigations suggest possible long-range transport of microorganism from the viewpoint of biological science, but from those, quantitative information such as concentration, size, mixing features, and others are hardly possible to be deduced. It is desired to make integrated observations such as Dunhuang campaign at downwind region: Japan, Korea, and others.

During the observation, cultivation of the samples collected in the boundary mixing layer, including cultivation in the media of NaCl solutions, observation of 16S ribosomal DNA (rDNA) sequence of materials analyzed by degenerate gradient gel electrophoresis method, identification of 16S and 18S rDNA sequence on total aerosols collected, and others, were tried in order to understand the diversity of microorganisms in the atmosphere over the desert areas (Maki et al. 2008; Kakikawa et al. 2008). Knowledge of the diversity of microbiota in the atmosphere of both downwind regions and the dust source region is essential in discussing the effect of long-range transport of dust–microorganism mixture on the ecosystems of the downwind regions, and making systematic observation, in addition to the measurements at Dunhuang, China, is needed at downwind regions.

Here, the relation of chemical–physical features of Kosa and bioaerosols, relating with problems 1, 2, 3, and 4 pointed above, is not studied, but it is very important to know the relation to understand the biological activities and biodiversity of microorganisms on Kosa surface. Life or death of microorganisms on Kosa surface, corresponding to

problem 5, cannot be observed here, and concentration estimated here contains both. Distinguishing life and death is very important in discussing the effects of microorganisms on ecosystem and the health hazards in downwind regions.

The concept of Kosa–microbiota mixture needs to be made much clearer in order to understand the ecosystem of microbiota and/or diversity of microbiota on the surface of single Kosa particles in future. Here, features of the distribution patterns of fluorescence spots on the Kosa particles were not investigated, and we defined as Kosa–microbiota mixture the Kosa particles showing fluorescence spot(s). It is desired in future to make much detailed discussion on the distribution patterns of fluorescence spots on dust particles.

In the present measurements, we could not obtain little information concerning intensities of solar UV radiations in the atmosphere. It will be very important factors in understanding environmental stress in which microbiota will accept during their long journey in the free atmosphere. Considering the mixing features of Kosa–microbiota mixture shown in the present measurements, it will be very hard work, from only a field observation, to clarify the solar UV shading effect of the Kosa particulate part of the mixture on the microorganisms living in the Kosa surface, and laboratory experiments to test the effect also will be effective.

Detailed discussion should be made in future concerning the relation between the characterization of Kosa particles (and/or Kosa particle surfaces) and diversity of microbiota on the particle surface to understand quantitatively the processes which make the long-range transport of microorganisms possible.

There have been few observations of atmospheric microbiota made in desert regions and little information concerning geographical, seasonal, and vertical difference in concentrations of microbiota and mixing state of dust and bioaerosol particles in the desert atmosphere. The results presented here are the first reports describing the behavior of microorganisms in the boundary atmosphere of the desert areas. The observations, however, are limited in the summer season and spatial scale of measurements covered only from near the ground (above sea level about 1 km) to a height of about 2 km (above sea level), and therefore, the results showed only case studies. As pointed out above, there still remain lots of important and interesting problems concerning bioaerosol or Kosa–bioaerosol mixture in the desert atmosphere. Integrated observations with various techniques in the desert atmosphere are desired in future.

Acknowledgments Our research was made on the financial supports by a Grant-in-Aid for Scientific Research (A) (20253005, PI, Y. I.)

and a Grant-in Aid for Encouragement of Young Scientists (20710024, PI, T. M.) from Ministry Education, Science, Sports, and Culture, Japan and Global Environment Research Fund (RF-072, PI, F. K.) from Ministry of the Environment, Japan. Heiwa Nakajima Foundation and Mistui Bussan Environmental Fund also support this research.

Staff members of Meteorological Bureau of Dunhuang City gave us kind technical supports during the balloon-borne observations.

Open Access This article is distributed under the terms of the Creative Commons Attribution Noncommercial License which permits any noncommercial use, distribution, and reproduction in any medium, provided the original author(s) and source are credited.

References

- Amato P, Hennebelle R, Magand O, Sancelme M, Delort A-M, Barbante C, Boutron C, Ferrari C (2007) Bacterial characterization of the snow cover at Spitzberg, Svalbard. *FEMS Microbiol Ecol* 59(2):255–264
- Ariya PA, Amyot M (2004) New directions: the role of bioaerosols in atmospheric chemistry and physics. *Atmos Environ* 38:1231–1232 doi:10.1016/j.atmosenv.2003.12.006
- Elbert W, Taylor PE, Andreae MO, Pöschl U (2007) Contribution of fungi to primary biogenic aerosols in the atmosphere: wet and dry discharge spores, carbohydrates, and inorganic ions. *Atmos Chem Phys* 7:4569–4588
- Fuzzi S, Andreae MO, Huebert BJ, Kulmala M, Bond TC, Boy M, Doherty SJ, Gunther A, Kanakidou M, Kawamura K, Kerminen V-M, Lohmann U, Russell LM, Pöschl U (2006) Critical assessment of the current state of scientific knowledge, terminology, and research needs concerning the role of organic aerosols in the atmosphere, climate, and global change. *Atmos Chem Phys* 5:11729–11780
- Griffin DW, Garisson VH, Herman JR, Shinn EA (2001) African desert dust in the Caribbean atmosphere: microbiology and public health. *Aerobiologia* 17:203–213 doi:10.1023/A:1011868218901
- Heubert BJ, Bates T, Russell PB, Shi G-Y, Kim YJ, Kawamura K, Cermichael G, Nakajima T (2003) An overview of ACE-Asia: strategies for quantifying the relationships between Asian aerosols and their climatic impacts. *J Geophys Res* 108:8633 doi:10.1029/2003JD003550
- Hua NP, Kobayashi F, Iwasaka Y, Shi G-Y, Naganuma T (2007) Detailed identification of desert-originated bacteria carried by Asian dust storms to Japan. *Aerobiologia* 23:291–293 doi:10.1007/s10453-007-9076-9
- Iwasaka Y, Minoura H, Nagaya K (1984) The transport and special scale of Asian dust-storm clouds: a case study of the dust storm event of April 1979. *Tellus* 35B:189–196
- Iwasaka Y, Yamato M, Imasu R, Ono A (1988) Transport of Asian dust (KOSA) particles; importance of weak KOSA events on the geochemical cycle of soil particles. *Tellus* 40B:494–503
- Iwasaka Y, Shibata T, Nagatani T, Shi G-Y, Kim YS, Matsuki A, Trochkin D, Zhang D, Yamada M, Nagatani M, Nakata H, Shen Z, Li G, Chen B, Kawahira K (2003a) Large depolarization ratio of free tropospheric aerosols over the Taklimakan desert revealed by lidar measurements: possible diffusion and transport of dust particles. *J Geophys Res* 108:8652 doi:10.1029/2002JD003267, ACC20 1-8
- Iwasaka Y, Shi G-Y, Yamada M, Matsuki A, Trochkin D, Kim Y-S, Zhang DD, Nagatani T, Shibata T, Nagatani M, Nakata H, Shen Z, Li G, Chen B (2003b) Importance of dust particles in the free

- troposphere over the Taklamakan Desert: Electron microscopic experiments of particles collected with a balloon-borne particle impactor at Dunhuang, China. *J Geophys Res* 108:8644
- Iwasaka Y, Li JM, Shi G-Y, Kim Y-S, Matsuki A, Trochkin D, Yamada M, Zhang DD, Nagatani T, Shibata T, Nagatani M, Nakata H, Shen Z, Hong CS (2008) Mass transport of background Asian dust revealed by balloon-borne measurement: dust particles transported during calm periods by westerly from Taklamakan desert. In: Kim YJ, Platt U (eds) *Advanced environmental monitoring*. Springer, Berlin, pp 121–135
- Jaenicke R (2005) Abundance of cellular material and proteins in the atmosphere. *Science* 308:73 doi:10.1126/science.1106335
- Kakikawa M, Kobayashi F, Maki T, Yamada M, Higashi T, Chen B, Shi G-Y, Hong C, Tobo Y, Iwasaka Y (2008) Dustborne microorganisms in the atmosphere over Asian dust source region, Dunhuang. *Air Quality, Atmosphere and Health* 1:195–202 doi:10.1007/s11869-008-0024-9
- Kanakidou M, Seinfeld JH, Pandis SN, Barnes I, Dentener FJ, Nielsen CJ, Swietlicki E, Putaud JP, Balkanski Y, Fuzzi S, Horth J, Mootgat GK, Winterhalter R, Myhre CEL, Tsigaridis K, Viganti E, Stephanou EG, Wilson J (2005) Organic aerosol and global climate modeling: a review. *Atmos Chem Phys* 5:1053–1123
- Keene WC, Galloway JN (1988) The biogeochemical cycling of formic and acetic acids through the troposphere: an overview of current understanding. *Tellus* 40B:322–334
- Kellogg CA, Griffin DW (2006) Aerobiology and the global transport of desert dust. *Trends Ecol Evol* 21:638–644 doi:10.1016/j.tree.2006.07.004
- Kim YS, Iwasaka Y, Shi G-Y, Nagatani T, Shibata T, Trochkin D, Matsuki A, Yamada M, Chen B, Zhang D, Nagatani M, Nakata H (2004) Dust particles in the free atmosphere over desert areas on the Asian continent: measurements from summer 2001 to summer 2002 with balloon-borne optical particle counter and lidar, Dunhuang, China. *J Geophys Res* 109:D19S26 doi:10.1029/2002JD003269
- Kobayashi F, Maki T, Kakikawa M, Higashi T, Yamada M, Shi G-Y, Iwasaka Y (2008) Micro organisms and Kosa particles revealed through balloon-borne measurements at Dunhuang, China (in Japanese), Proceedings of the 49th Annual Meeting of Japan Society for Atmospheric Environment. Kanazawa, Japan, pp 70–71
- Lohmann U, Feichter J (2005) Global indirect aerosol effects: a review. *Atmos Chem Phys* 5:715–735
- Maki LR, Galyan EL, Chang-Chien MM, Caldwell DR (1978) Ice nucleation induced by *Pseudomonas syringae*. *Appl Environ Microbiol* 28:456–459
- Maki T, Suzuki S, Kobayashi F, Kakikawa M, Yamada M, Higashi T, Chen B, Shi GY, Tobo Y, Hasegawa H, Ueda K, Iwasaka Y (2008) Phylogenetic diversity and vertical distribution of a halobacterial community in the atmosphere of an Asian dust (KOSA) source region, Dunhuang city, air quality. *Atmosphere Health* 1:81–89 doi:10.1007/s11869-008-0016-9
- Mikami M, Shi GY, Uno I, Yabuki S, Iwasaka Y, Yasui M, Aoki T, Tanaka TY, Krosaki Y, Masuda K, Uchiyama A, Matsuki A, Sakai T, Takemi T, Nakawo M, Seino N, Ishizuka M, Satake S, Fujita K, Hara Y, Kai K, Kanayama S, Hayashi M, Du M, Kanai Y, Yamada Y, Zhang XY, Shen Z, Zhou H, Abe O, Nagai T, Tsutsumi Y, Chiba M, Suzuki J (2006) Aeolian dust experiment on climate impact: an overview of Japan–China joint project ADEC. *Glob Planet Change* 52:142–172 doi:10.1016/j.glopla.cha.2006.03.001
- Möhler O, Demott PJ, Vali G, Levin Z (2007) Microbiology and atmospheric processes: the role of biological particles in cloud physics. *Biogeosciences* 4:1059–1071
- Okada K, Kai K (1995) Features and elemental composition of mineral particles collected in Zhangye, China. *J Meteorol Soc Jpn* 73:947–957
- Porter KG, Feig YS (1980) The use of DAPI for identifying and counting aquatic microflora. *Limnol Oceanogr* 25:943–948
- Prospero JM, Blades E, Mathison G, Naidu R (2005) Interhemispheric transport of viable fungi and bacteria from Africa to Caribbean with soil dust. *Aerobiologia* 21:1–19 doi:10.1007/s10453-004-5872-7
- Russell NJ, Newman C, Williamson DH (1974) A simple cytochemical technique for demonstration of DNA in cells infected with mycoplasmas and viruses. *Nature* 253:461–462 doi:10.1038/253461a0
- Skidmore ML, Foght JM, Sharp MJ (2000) Microbial life beneath a high Arctic glacier. *Appl Environ Microbiol* 66:3214–3220 doi:10.1128/AEM.66.8.3214-3220.2000
- Sokolik I, Winker D, Bergametti G, Gillette D, Carmichael G, Kaufman Y, Gomes L, Schuetz L, Penner J (2001) Introduction to special section: outstanding problems in quantifying the radiative impacts of mineral dust. *J Geophys Res* 106:18015–18027 doi:10.1029/2000JD900498
- Sun J, Ariya PA (2006) Atmospheric organic and bioaerosols as cloud condensation nuclei (CCN): a review. *Atmos Environ* 40:795–820 doi:10.1016/j.atmosenv.2005.05.052
- Sun J, Zhang M, Liu T (2001) Spatial and temporal characteristics of dust storms in China and its surrounding regions, 1960–1999: relations to source area and climate. *J Geophys Res* 106:10325–10333 doi:10.1029/2000JD900665
- Toom-Sauntry D, Barrie LA (2002) Chemical composition of snowfall in the high Arctic: 1990–1994. *Atmos Environ* 36:2683–2693 doi:10.1016/S1352-2310(02)00115-2
- Uno I, Amano H, Emori S, Kinoshita K, Matsui I, Sugimoto N (2001) Trans-Pacific yellow sand transport observed in April 1998: a numerical simulation. *J Geophys Res* 106:18331–18344 doi:10.1029/2000JD900748
- Uno I, Satake S, Carmichael GR, Tan Y, Wan Z, Takemura T, Sugimoto N, Shimizu A, Murayama T, Cahill T, Cliff S, Uematsu M, Ohta S, Quinn P, Bates T (2004) Numerical study of Asian dust transport during the springtime of 2001 simulated with the CFORS model. *J Geophys Res* 109:D19S24 doi:10.1029/2003JD00422
- Wu P-C, Tsai J-C, Li F-C, Lung S-C, Su H-J (2004) Increased levels of ambient fungal spores in Taiwan are associated with dust event from China. *Atmos Environ* 38:4879–4886 doi:10.1016/j.atmosenv.2004.05.039
- Yamada M, Iwasaka Y, Matsuki A, Trochkin D, Kim YS, Zhang D, Nagatani T, Shi G-Y, Nagatani M, Nakata H, Shen Z, Chen B, Li G (2005) Feature of dust particles in the spring free troposphere over Dunhuang in northwestern China: electron microscopic experiments on individual particles collected with a balloon-borne impactor. *Water Air Soil Pollut Focus* 5:231–250 doi:10.1007/s11267-005-0741-0
- Yeo H-G, Kim J-H (2002) SPM and fungal spores in the ambient air of west Korea during the Asian Dust (Yellow Sand) period. *Atmos Environ* 36:5437–5442 doi:10.1016/S1352-2310(02)00672-6
- Zhang S, Hou S, Ma X, Qin D, Chen T (2007) Culturable bacteria in Himalayan glacial ice in response to atmospheric circulation. *Biogeosciences* 4:1–9