

Haptic threshold for pulling force feedback on surgeon's fingertip in medical robotic systems

メタデータ	言語: eng 出版者: 公開日: 2017-10-03 キーワード (Ja): キーワード (En): 作成者: メールアドレス: 所属:
URL	http://hdl.handle.net/2297/47082

Haptic threshold for pulling force feedback on surgeon's fingertip in medical robotic systems

Hiroyuki Chinbe, Takeshi Yoneyama, and Tetsuyou Watanabe

Faculty of Mechanical Engineering
Institute of Science and Engineering
Kanazawa University, Ishikawa, Japan

{zaqxs@stu & yoneyama@se}.kanazawa-u.ac.jp; te-watanabe@ieee.org

Mitsutoshi Nakada

Faculty of Medicine, Institute of Medical,
Pharmaceutical and Health Sciences,
Kanazawa University, Ishikawa, Japan

Abstract—The human fingertip has very high density of the receptor to accept sense of touch stimulation. The corresponding somatic sensory area in a brain is very large, and considered to be a specialized part for palpation. A lot of haptic display system then have been developed with the investigation of human haptic perception. However, the researches about the human perception for pulling force at grasping, namely static frictional force are limited. This paper investigated it, aiming at a future development of pulling and grasping force feedback system for neurosurgical robotic systems. For the purpose, this paper explored the possibility of displaying pulling force to an index finger during grasping. The absolute and difference thresholds for pulling sense were the targets. The results showed that grasping disturbs the pulling sense, and the sides of index fingertip can be used to display pulling sense, relatively large force, namely scaled force feedback is required for the perception. The results provide an important insight at a hardware and controller design of force feedback systems.

Keywords— *haptic threshold; pulling sense; finger-tip; surgical robot; force feedback;*

I. INTRODUCTION

Robotic surgical systems require only small holes on patients for operations, and provide invasive endoscopic operations and short hospital stays [1-2]. Additionally, surgeons can also have several merits including magnified visual feedback information and motion modification (large motion is scaled to small motion and vibration of motions is reduced). However, the forceps of the robotic system are controlled indirectly through the system, and surgeons cannot get (real) haptic or force information [3]. It could reduce the performance of operations. To realize real safe and precise operations, haptic or force feedback systems are crucial. Many researchers then have developed haptic and force feedback systems for medical robots [4-14]. Our group also developed haptic or force feedback systems [15-18] for an endoscopic neurosurgery. In the fields of endoscopic neurosurgery, the manipulator with forceps has to go through narrow routes and to work at small and narrow surgical fields. High precise control is obviously required. Our developed manipulator has 5 D.O.F (degree of freedom), and its diameter is 3 [mm], as shown in Fig. 1. Force sensors are embedded in forceps and grasping and pulling forces can be measured (see

Fig. 2). The grasping force is feedbacked to an index finger as a kinesthetic sense via motors while pulling force is feedbacked to an index finger as a shear sensation by a friction roller. In this case, surgeons or operators feel the combined senses. However, the validity of this methodology was not investigated. The preliminary experiment investigating whether grasping and pulling force can be felt in our robotic system showed that all participants got the sense of grasping while some of participants could not get the sense of pulling. Therefore, how to feedback the pulling sense is a problem. The assessment of appropriate methodologies and devices realizing them are needed. With this in mind, this paper investigates how pulling sense should be feedbacked or displayed during grasping.

According to the opinions of neurosurgeons (coauthors), pulling force is significant to understand the softness of tissue. Softness of tumors and that of normal tissues are different and the detection of the softness is very important to detect the boundary between normal tissues and tumors. The human fingertip has very high density of the receptor to accept sense of touch stimulation. Its corresponding somatic sensory area in a brain is very large, and considered to be a specialized part for palpation. A lot of haptic feedback or display systems have been developed with the investigation of haptic mechanisms [19-23]. However, most of the targets were sliding senses, namely a feedback of kinetic frictional forces. To the best of the authors' knowledge, the results concerning with a feedback of static frictional forces (pulling sense) are limited. From this viewpoint, the investigation of pulling sense feedback methodologies is an important issue at force feedback systems. This paper focuses on this point. Concretely, this paper tries to explore the following things.

- Possibility of displaying the pulling force to an index finger during grasping, via the investigation of absolute and difference thresholds
- Are sides of index finger available for force displaying area?
- The necessity and amount of scaling of feedbacked force to give a pulling sense at an operation device which does not allow natural grasping styles.

The target force feedback system is for our developed system shown in Fig.1. The investigation results (are very important) could be useful to develop force feedback systems including pulling sense display, although the useable situations could be limited to the systems similar to our system. The remaining of this paper is organized as follows. The subsequent section describes target robotic system. The investigations of absolute and difference thresholds for pulling sense were then presented. After the results are discussed, summary is presented.

II. TARGET ROBOTIC SYSTEMS FOR NEUROSURGERY

The final goal is the development of grasping and pulling forces feedback system for our developed robotic system for neurosurgery shown in Fig. 1. The system consists of the operation device (master system) and the micro manipulator (slave system). The slave manipulator has 5 D. O. F. including forward-backward motion, bending motion, two rotational motions at the root and tip of manipulator, and gripping. The master operation device was designed so that their motions can correspond to the motions of the slave manipulators. At the forceps of the slave manipulator, there are strain gauges for measuring grasping and pulling forces (see Fig. 2). The measured forces are feedbacked to operators. This paper deals with this force feedback system, and find out appropriate methodology for the feedback. Therefore, displaying the forces at index finger are considered here. The controller was based on force reflecting servo and virtual impedance controllers. See [15] for the detail of the controller.

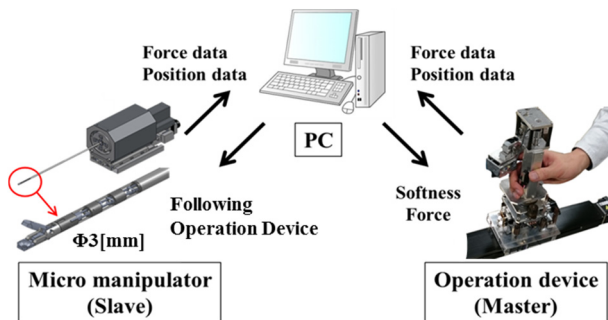

Fig. 1. Robotic system for neurosurgery [15-18]

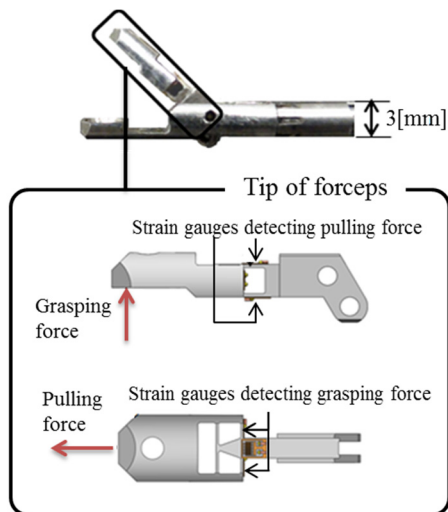

Fig. 2. Force sensors attached on the forceps of the slave manipulator[15-18]

III. INVESTIGATION OF ABSOLUTE THRESHOLD OF PULLING FORCE DURING GRASPING

First, absolute threshold of pulling force was assessed when pulling and grasping force are applied simultaneously.

A. Participants

Eight Japanese volunteers (seven men and one woman, mean age 22 ± 1 years (from 21 to 23 years)) participated in the experiments. They were all right-handed, and none of them reported any difficulties with their hands and haptics. The experiments were approved by the Medical Ethics Committee of Kanazawa University.

B. Conditions

Fig. 3 shows the examined styles for displaying or feedbacking pulling force. The measurement of grasping and pulling force is conducted at forceps, and they can correspond to thumb and index fingers. Therefore, this paper focused on displaying or feedbacking at thumb or index finger. As well known, index finger has the most number of haptic receptors among fingers and its distribution density is also the largest [24-25]. We then placed a weight on assessing the possibility of displaying the grasping and pulling forces at index finger. Displaying only for index fingers can reduce the size and complexity of the total force feedback system, and the way can correspond to the structure of our developed systems shown in Figs. 1 and 2. The detail of the candidates of styles are as follows;

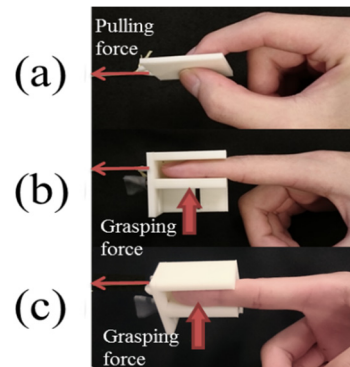

Fig. 3. Examined styles for displaying pulling force.

Fig. 3 (a): A thin plate was grasped by thumb and index fingers, then the grasped plate was pulled. The participants felt the pulling force at the pads of thumb and index fingers. The magnitude of grasping force was determined by each participant.

Fig. 3 (b): The pad and nail of index finger was pinched by a handmade fixture, and the fixture was pulled. The magnitude of pinching force was selected by each participant so that the influence of pitching (such as discomfort) could be minimized. The participants felt the pulling force at the pad and nail of index finger. Grasping force (in addition to the pitching force) was applied to the fixture part corresponding to the pad of index fingertip in a lateral direction.

Fig. 3 (c): The sides of index finger was pinched by a handmade fixture, and the fixture was pulled. The participants felt the

TABLE I. EXPERIMENTAL CONDITIONS

Condition Number	Notation	Displaying area for pulling force	Grasping force	Cushion inside fixture
1	T&I	The pads of thumb and index fingers	Up to participants	-
2	P&N(0N)	The pad and nail of index fingers	0 N	None
3	P&N(3N)	The pad and nail of index fingers	3 N	None
4	P&N(0N)+C	The pad and nail of index fingers	0 N	Cushion
5	P&N(3N)+C	The pad and nail of index fingers		

pulling force at the sides of index finger. Grasping force was applied to the pad of index fingertip in a lateral direction.

In the medical robotic systems, force feedback is passively operated, and there is no active intention of operators, especially when slave manipulator encounters unexpected tissues and there is no active force. Therefore, passive force feedback is appropriate for investigation. Fig. 3 (b) and (c) correspond to passive force feedback. We set up additional several conditions regarding to Fig. 3 (b) and (c). Experiments were carried out in the cases that the grasping force was 0 and 3 N. 3 N corresponds to the maximum displayable grasping force in our robotic system show in Fig. 1. The effect of existing of cushion inside the fixture was also investigated in order to see the effect of softness at the fixing area for index fingertip. The cushion was made by composing silicone (Shin-Etsu Co. KE-1308) and hardener (Shin-Etsu Co. CAT1300-3).

Fig. 3 (a) means a natural grasping style where pulling force is passively applied while grasping force is actively applied. The participants actively applied grasping force with preferable magnitude, and paid larger attention to the pulling force. Therefore, the best sensitivity can be expected in the style. However, the displaying style shown in Fig. 3 (a) can be took only when a thickness of grasped object is close to that for the plate. When grasping is not performed, this style cannot be applied. Therefore, the style shown in Fig. 3 (a) is difficult to be applied in real force feedback systems. Nonetheless, we need to know the sensitivity in natural style, and we then examined this style as a reference.

Table I shows the summarized experimental conditions with the notation of the condition.

C. Apparatus

Fig. 4 shows the schematic view of experimental set up when the style was Fig. 3 (b). The other cases were similarly set up. Each participant gripped a pole to fix the position of wrist so that the set up could correspond to our developed system shown in Fig. 1. At the index finger, the handmade fixture was attached so that the pad and nail of the index finger could feel pulling force. The fixture was made from ABS plastic with 3D printer (Stratasys UPrintSE). The structure and dimensions of the plate (which was also made of the same 3D printer) for the style of Fig. 3 (a) are shown in Fig. 5, and those of the fixture for the styles of Fig. 3 (b) and (c) are shown in Fig. 6. Both the plate and fixture have a hook to display pulling force by pulling them. The dimension for the plate was determined so that adult human can have a space for grasping. The dimension for the fixture was determined to have an enough space to fit index fingertip of adult human in it. The fixture has an adjuster to fit the thickness

of individual fingertip. Its range was 0 – 29 mm. Fig. 7 shows the fabricated plate and fixture. The plate and fixture were pulled by DC motor (Maxon A-max22) fixed on a vise through a wire. The output torque of DC motor was controlled by motor controller (Maxon 4-Q-DC Servo Control LSC 30/2). A handmade force sensor shown in Fig.8 was attached at the intermediate point of the wire, in order to measure pulling force. The sampling time for the force sensor was 5ms, and torque control was used to control the DC motor. Note that the time constant ($61.2 \mu\text{s}$) is so small that the acceleration time can be ignored, and the pulling force corresponding to the torque driven at the DC motor was then directly applied. The dimension and structure of the force sensor were shown in Fig.8. Force gauge (IMADA DS2-50N) was fixed at a positioning stage to control grasping force when the style was Fig. 3 (b) and (c). The grasping force (3N) at the style of Fig. 3 (b) and (c) was controlled by the participant oneself. The grasping force was applied to the fixture part corresponding to the pad of index finger at the style of Fig. 3 (b) while it was applied to the pad of index finger at the style of Fig. 3 (c). It should be noted that the index finger was pre-compressed by the fixture, and the value of grasping force (0 or 3 N) then means the value without taking the pre-compression into account. A switch was prepared so that participant can inform the point where she/he detect the force or the change of force.

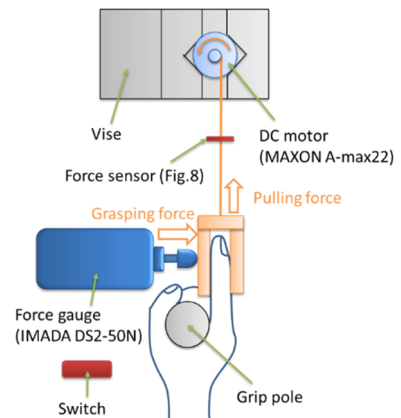

Fig. 4. Schematic view of experimental set up.

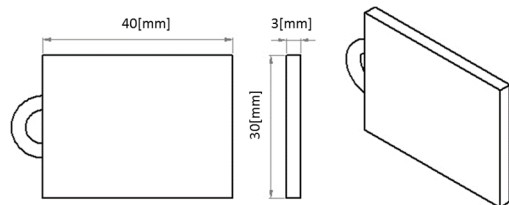

Fig. 5. Plate for the style shown in Fig. 3 (a)

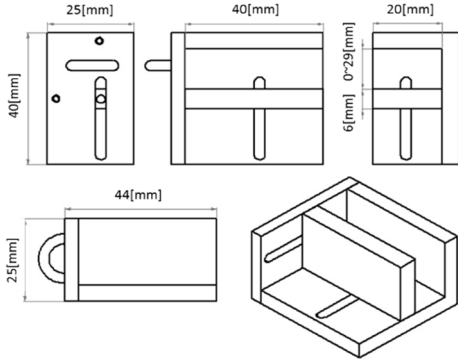

Fig. 6. Fixture for the styles shown in Fig. 3 (b) and (c)

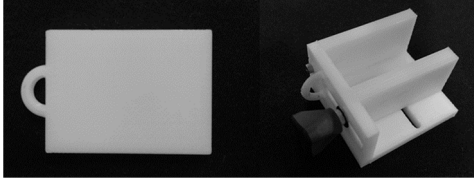

Fig. 7. Fabricated plate (left) and fixtures (right).

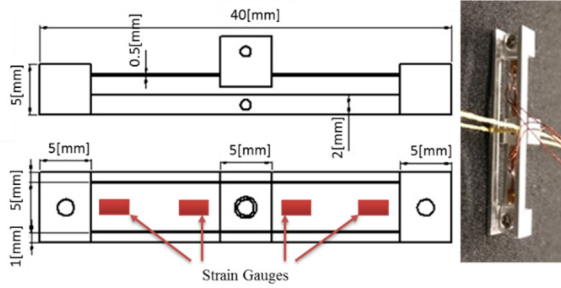

Fig. 8. Dimension and structure of force sensors for measuring pulling force.

D. Procedure

The method of limits was used to identify absolute threshold of pulling force. During the experiment, the participants closed their eyes to remove the effects of visual information. Initially, there is no pulling force. We increased the magnitude of pulling force by the DC motor so that the applied magnitude could be ascending series with the speed of 0.1N/sec. The stimulus (pulling force) was continuously increased, but the starting time for giving the stimulus was randomly selected so that the participants couldn't predict the stimulus. Random starting time to display the stimulus was announced to the participants in advance. The participants pushed the switch when she/he felt pulling force at first time, and we recorded the magnitude of pulling force at the time. Note that the experiment was conducted one time for practice. After the practice, the experiment was conducted three times per person. We evaluated mean value of obtained pulling force as the absolute threshold.

E. Results

Fig. 9 shows the results showing mean absolute threshold of 8 participants with standard deviation. Small threshold indicates that the participants could response sensitively. The smallest absolute threshold was obtained when the plate was grasped by thumb and index fingers (T&I). As described the above, this is the reference. It can be seen how sensitivity reduced comparing

to this reference. In order to evaluate the effects of “displaying area”, the existing of “grasping force”, and “cushion”, t-test was conducted paired t-test for the pairs listed in Table II. No significant difference was statistically obtained between [P&N(0/3N)+C] (the pulling force was applied to the pad and nail with cushion) and [side (0/3N)+C] (the pulling force was applied to the sides with cushion). If focusing on the effect of grasping force and comparing the cases when the grasping force was 0 and 3 N, it can be seen that grasping reduced the sensitivity of absolute threshold (the absolute threshold increased). There was a statistical significant difference between [P&N(0N)+C] and [P&N(3N)+C] while no significant difference between [Side(0N)+C] and [Side(3N)+C]. It indicates displaying to the sides of finger can reduce the influence of grasping force. The insertion of cushion made the small increase of absolute threshold, but no significant difference was detected.

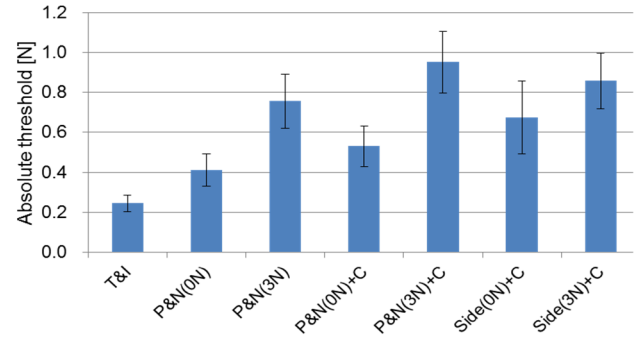

Fig. 9. Obtained absolute threshold of pulling force

TABLE II. RESULTS OF PAIRED T-TEST REGARDING ABSOLUTE THRESHOLDS OF PULLING FORCE

Objective of t-test	Targeted sample 1	Targeted sample 2	Result
Grasping force	P&N(0N)	P&N(3N)	*P < 0.05
Grasping force	P&N(0N)+C	P&N(3N)+C	*P < 0.05
Grasping force	Side(0N)+C	Side(3N)+C	P = 0.21
Displaying area	P&N(0N)+C	Side(0N)+C	P = 0.17
Displaying area	P&N(3N)+C	Side(3N)+C	P = 0.24
Cushion	P&N(0N)	P&N(0N)+C	P = 0.073
Cushion	P&N(3N)	P&N(3N)+C	P = 0.21

IV. INVESTIGATION OF DIFFERENCE THRESHOLD OF PULLING FORCE DURING GRASPING

Next, difference threshold was identified. The participants, the experimental conditions, and the apparatus were the same as the previous experiments.

A. Procedure

The method of constant stimuli was used to get the difference threshold. Similarly to the previous experiment, the participants closed their eyes during the experiment. Initially, constant pulling force was applied for 5 seconds. Next, the magnitude of the pulling force randomly changed. The participants informed whether they could feel the change of pulling force. If they felt, they informed whether the pulling force increased or decreased. The difference of change in the pulling force incremented and decremented with the step of 0.1n N where n denotes a random integer. This procedure was

repeated until detecting the difference of change where the accuracy rate of the response got to more than 80 %. We let the detected difference be the difference threshold of pulling force. The experiments were conducted at the cases when the initial constant pulling force was 1 and 2 N.

B. Results

Fig. 10 shows the results showing mean difference threshold of 8 participants with standard deviation. The yellow bars show the results when the initial constant pulling force ($f_{p_{ini}}$) was 1 N while the brown bars show the results when $f_{p_{ini}}$ was 2 N. As it can be seen that, the obtained results are very similar to the results for the previous experiment. The difference threshold for $f_{p_{ini}} = 2$ N is larger than that for $f_{p_{ini}} = 1$ N at all 7 cases, and a statistical significant difference was obtained as shown in Table III. The effect of grasping force was similar to the previous experiment. When the grasping force was required, the difference threshold increased. Different from the previous result, there was a statistical significant difference between [Side(0N)+C] and [Side(3N)+C]. On the other hand, there was no clear differences based on the differences of displaying areas and existing of cushion.

V. DISCUSSION

Two experimental results indicate that if displaying pulling force with more than 1 N, operators can feel pulling even when grasping is performing, and if increasing the pulling force with increasing amount of more than 1.5 N, operators can detect the change of pulling force. These information is very useful in construction of force feedback controller; how scaling of forces should be done.

From the experiment for identifying a difference threshold, it can be seen that the increase of magnitude of initial constant stimulus decreased the difference threshold. The results can correspond to Weber–Fechner law [26] that a psychophysical sensation intensity is proportional to not the strength of stimulus but the logarithm of that. Note that further experiments including the cases of $f_{p_{ini}} = 3, 4, \dots$ N are needed for more accurate understanding.

If focusing on the effect of grasping, grasping operation reduced both the absolute and difference thresholds. The participants had to feel two kinds of sense at the same index finger at the same time. This might be considered to proceed a kind of misunderstanding.

Next, the displaying area for pulling force is focused. If no grasping was operated, the absolute and difference thresholds when the displaying area was the pad and nail of index finger was smaller than that when the displaying area was the sides. However, if grasping was required, their values were very close. It indicates that the sides of index finger have low sensitivity for absolute threshold but the effect of grasping is low. They then could have a sensitivity nearly equal to that at the pad and nail of index fingers during grasping. Another reason is that the area feeling pulling force was different from the area feeling grasping force. The results give an important indication for the validity of the methodology that pulling force is displayed at the sides of index finger.

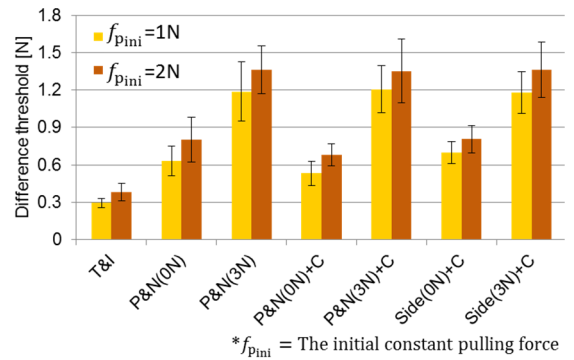

Fig. 10. Obtained difference threshold of pulling force

TABLE III. RESULTS OF PAIRED T-TEST REGARDING DIFFERENCE THRESHOLDS OF PULLING FORCE

Objective of t-test	$f_{p_{ini}}$	Targeted sample 1	Targeted sample 2	Result
Grasping force	1N	P&N(0N)	P&N(3N)	*P < 0.01
Grasping force	2N	P&N(0N)	P&N(3N)	*P < 0.01
Grasping force	1N	P&N(0N)+C	P&N(3N)+C	*P < 0.01
Grasping force	2N	P&N(0N)+C	P&N(3N)+C	*P < 0.05
Grasping force	1N	Side(0N)+C	Side(3N)+C	*P < 0.01
Grasping force	2N	Side(0N)+C	Side(3N)+C	*P < 0.05
Displaying area	1N	P&N(0N)+C	Side(0N)+C	P = 0.097
Displaying area	2N	P&N(0N)+C	Side(0N)+C	P = 0.10
Displaying area	1N	P&N(3N)+C	Side(3N)+C	P = 0.78
Displaying area	2N	P&N(3N)+C	Side(3N)+C	P = 0.96
Cushion	1N	P&N(0N)	P&N(0N)+C	P = 0.062
Cushion	2N	P&N(0N)	P&N(0N)+C	P = 0.62
Cushion	1N	P&N(3N)	P&N(3N)+C	P = 0.36
Cushion	2N	P&N(3N)	P&N(3N)+C	P = 0.82
$f_{p_{ini}}$	-	All cases ($f_{p_{ini}}=1$ N)	All cases ($f_{p_{ini}}=2$ N)	*P < 0.01

If considering the effect of cushion, there was no clear difference between the cases when a cushion was inserted and when it was not. It indicates that hardness around the fitting between the fixture (or cushion) and fingertip does not contribute to the sensitivities related with the absolute and difference thresholds of pulling force.

As expected, the best sensitivity was obtained when the thin plate was grasped by thumb and index fingers. The pads of fingers have the largest number of haptic receptors [25]. Additionally, the participants actively determined grasping force with preferable (probably optimal) magnitude, and paid larger attention to the pulling force. These might be the reasons. From another viewpoint, the results for this case can be regarded as optimal or lowest absolute and difference thresholds for pulling force, when grasping was performed at the same time. The large difference with the other displaying styles or experimental conditions indicates that grasping and unordinary style reduce the sensitivity. It can be understood that more than twice magnitude was required to detect and differentiate pulling forces with the style shown in Fig. 3 (b) and (c), comparing to the (natural) style shown in Fig. 3 (a).

If considering the development of a (pulling) force feedback system for our developed neurosurgical robotic system, [Side+C] (see Table I) might be the best solution. Although the pad has a lot of haptic receptors, grasping dramatically reduced the sensitivity as the experimental results showed. For easiness

of design and fabrication, a display system for grasping force and that for pulling force should be separated. If taking both design and human perception into account, a grasping force should be displayed at the fingertip pad while a pulling force should be displayed at the sides of fingertip. If minding the frequency response of human (about 10 Hz), the frequency response of 200 Hz (corresponding to the experiment setting in this paper) might be enough for the (pulling) force feedback system.

VI. CONCLUSION

This paper investigated sensorial properties of human when pulling force sensation was displayed, aiming at the future development of pulling force feedback system for our neurosurgical robotic systems. The primal target application was our own system. The obtained results of human perception can be valid and useful on developing other (pulling) force feedback systems, although applicable cases were limited to the systems similar to our system. Additionally the investigation was limited to the cases when the contact area was rigid, and we ignored the effect of softness of target objects. The investigation including the effect of contact softness would be one of our future works. The main results were that grasping reduced the sensitivity to pulling force and more than twice magnitude was required to detect and differentiate pulling forces. The sides of fingertips can be used for displaying pulling forces. Especially when displaying pulling force with grasping force, the sensitivity at the sides was equal to the one at the pads where grasping and pulling forces were simultaneously displayed. We also understood that large magnitude of pulling force should be displayed when grasping and pulling forces were simultaneously displayed at index finger. The scaling of feedbacked force is required to get a clear sensation. The results indicate that the method of displaying pulling force at sides of index fingertip might be a good solution. The implementation of the results on the robotic system might be one of our future works.

REFERENCES

- [1] A. Cuschieri, "Whither minimal access surgery: tribulations and expectations.," *Am. J. Surg.*, vol. 169, no. 1, pp. 9–19, Jan. 1995.
- [2] A. Moreno-Egea, J. A. Torralba, G. Morales, T. Fernández, P. Guzmán, G. Hita, E. Girela, M. Corral, A. Campillo, and J. L. Aguayo, "Laparoscopic repair of secondary lumbar hernias: open vs. laparoscopic surgery. A prospective, nonrandomized study," *Cirugía española*, vol. 77, no. 3, pp. 159–62, Mar. 2005.
- [3] D. M. Herron and M. Marohn, "A consensus document on robotic surgery," *Surg. Endosc.*, vol. 22, no. 2, pp. 313–325, Feb. 2008.
- [4] C. R. Wagner, N. Stylopoulos, and R. D. Howe, "The role of force feedback in surgery: analysis of blunt dissection," in *Proceedings 10th Symposium on Haptic Interfaces for Virtual Environment and Teleoperator Systems. HAPTICS 2002*, pp. 68–74.
- [5] A. Kazi, "Operator Performance in Surgical Telemicrosurgery," *Presence Teleoperators Virtual Environ.*, vol. 10, no. 5, pp. 495–510, Oct. 2001.
- [6] T. Hu, G. Tholey, J. P. Desai, and A. E. Castellanos, "Evaluation of a laparoscopic grasper with force feedback," *Surg. Endosc.*, vol. 18, no. 5, pp. 863–867, May 2004.
- [7] B. Demi, T. Ortmaier, and U. Seibold, "The touch and feel in minimally invasive surgery," in *IEEE International Workshop on Haptic Audio Visual Environments and their Applications*, 2005, pp. 33–38.
- [8] G. De Gerssem, H. Van Brussel, and F. Tendick, "Reliable and Enhanced Stiffness Perception in Soft-tissue Telemicrosurgery," *Int. J. Rob. Res.*, vol. 24, no. 10, pp. 805–822, Oct. 2005.
- [9] T. Haidegger, L. Kovacs, G. Fodor, Z. Benyo, and P. Kazanzides, "Future Trends in Robotic Neurosurgery," in *14th Nordic-Baltic Conference on Biomedical Engineering and Medical Physics*, Berlin, GER: Springer, 2008, pp. 229–233.
- [10] J. Fachinger, M. den Exter, B. Grambow, S. Holgersson, C. Landesman, M. Titov, and T. Podruzhina, "Behaviour of spent HTR fuel elements in aquatic phases of repository host rock formations," *Nucl. Eng. Des.*, vol. 236, no. 5–6, pp. 543–554, Mar. 2006.
- [11] K. Hongo, Y. Kakizawa, J. Koyama, K. Kan, K. Nishizawa, F. Tajima, M. G. Fujie, and S. Kobayashi, "Microscopic-manipulator system for minimally invasive neurosurgery: preliminary study for clinical application," *Int. Congr. Ser.*, vol. 1230, pp. 275–280, Jun. 2001.
- [12] K. Hongo, S. Kobayashi, Y. Kakizawa, J.-I. Koyama, T. Goto, H. Okudera, K. Kan, M. G. Fujie, H. Iseki, and K. Takakura, "NeuroRobot: telecontrolled micromanipulator system for minimally invasive microneurosurgery-preliminary results.," *Neurosurgery*, vol. 51, no. 4, pp. 985–8; discussion 988, Oct. 2002.
- [13] K. Kan, M. G. Fujie, F. Tajima, K. Nishizawa, T. Kawai, A. Shose, K. Takakura, S. Kobayashi, and T. Dohi, "Development of HUMAN system with three micromanipulators for minimally invasive neurosurgery," *Int. Congr. Ser.*, vol. 1230, pp. 143–148, Jun. 2001.
- [14] A. Morita, S. Sora, M. Mitsuishi, S. Warisawa, K. Suruman, D. Asai, J. Arata, S. Baba, H. Takahashi, R. Mochizuki, and T. Kirino, "Microsurgical robotic system for the deep surgical field: development of a prototype and feasibility studies in animal and cadaveric models," *J. Neurosurg.*, vol. 103, no. 2, pp. 320–327, Aug. 2005.
- [15] T. Yoneyama, T. Watanabe, H. Kagawa, J. Hamada, Y. Hayashi, and M. Nakada, "Force detecting gripper and flexible micro manipulator for neurosurgery," in *2011 Annual International Conference of the IEEE Engineering in Medicine and Biology Society*, 2011, pp. 6695–6699.
- [16] T. Yoneyama, T. Watanabe, H. Kagawa, J. Hamada, Y. Hayashi, and M. Nakada, "Force-detecting gripper and force feedback system for neurosurgery applications," *Int. J. Comput. Assist. Radiol. Surg.*, vol. 8, no. 5, pp. 819–829, Sep. 2013.
- [17] Y. Yamashita, Y. Fujihira, T. Yoneyama, T. Watanabe, H. Kagawa, J. Hamada, Y. Hayashi, and M. Nakada, "Development of a Force Detecting Flexible Micromanipulator for the Resection of Brain Tumor," *Trans. Japanese Soc. Med. Biol. Eng.*, vol. 50, no. 4, pp. 329–336, 2012.
- [18] Y. Fujihira, T. Hanyu, Y. Kanada, T. Yoneyama, T. Watanabe, and H. Kagawa, "Gripping Force Feedback System for Neurosurgery," *Int. J. Autom. Technol.*, vol. 8, no. 1, pp. 83–94, Jan. 2014.
- [19] T. W. James, S. Kim, and J. S. Fisher, "The neural basis of haptic object processing.," *Can. J. Exp. Psychol. Can. Psychol. expérimentale*, vol. 61, no. 3, pp. 219–229, 2007.
- [20] M. Biet, F. Giraud, and B. Lemaire-Semail, "Implementation of tactile feedback by modifying the perceived friction," *Eur. Phys. J. Appl. Phys.*, vol. 43, no. 1, pp. 123–135, Jul. 2008.
- [21] A. Z. Hajian and R. D. Howe, "Identification of the Mechanical Impedance at the Human Finger Tip," *J. Biomech. Eng.*, vol. 119, no. 1, p. 109, 1997.
- [22] M. Morioka, D. J. Whitehouse, and M. J. Griffin, "Vibrotactile thresholds at the fingertip, volar forearm, large toe, and heel," *Somatosens. Mot. Res.*, vol. 25, no. 2, pp. 101–112, Jan. 2008.
- [23] C. Hatzfeld and R. Werthschützky, "Vibrotactile Force Perception Thresholds at the Fingertip," in *Haptics: Generating and Perceiving Tangible Sensations*, vol. 6191, Berlin, GER: Springer, 2010, pp. 99–104.
- [24] R. S. Johansson and Å. B. Vallbo, "Tactile sensory coding in the glabrous skin of the human hand," *Trends Neurosci.*, vol. 6, pp. 27–32, Jan. 1983.
- [25] A. B. Vallbo and R. S. Johansson, "Properties of cutaneous mechanoreceptors in the human hand related to touch sensation.," *Hum. Neurobiol.*, vol. 3, no. 1, pp. 3–14, 1984.
- [26] S. Dehaene, "The neural basis of the Weber–Fechner law: a logarithmic mental number line," *Trends Cogn. Sci.*, vol. 7, no. 4, pp. 145–147, Apr. 2003.