

High speed rotating disc type generator for high magnetic field

メタデータ	言語: English 出版者: 公開日: 2017-10-03 キーワード (Ja): キーワード (En): 作成者: Bessho, Kazuo, Yamada, Sotoshi, Miura, N. メールアドレス: 所属:
URL	http://hdl.handle.net/2297/48298

HIGH SPEED ROTATING DISC TYPE GENERATOR FOR HIGH MAGNETIC FIELD

Kazuo Bessho, Sotoshi Yamada and Norio Miura

Abstract - A high magnetic field generator based on a new idea is described in this paper. The principle of the generator is different from those of previously published or tested. The fundamental principle of generating a high magnetic field is that the magnetic flux induced by an electromagnet with an iron core is concentrated by eddy currents on a rotating conductive disc and is compressed to high magnetic flux density on the hole surrounded with four discs. The energy for concentrating a magnetic flux is fed from the kinetic energy of rotating discs. Therefore, the generator is non-destructive and has only a relatively small electric source. The high magnetic field has a long pulse duration.

INTRODUCTION

Recently, the progress of material science has required the technical developments of producing extreme physical conditions. The high magnetic field, one of the extreme conditions, is very important and attracts much attention because it is closely related to nuclear fusion and plasma physics.

Various high magnetic field generators have been used such as superconducting magnets and various kinds of pulse magnets which are made of normal metals. These generators, however, are expensive and are not easy to handle. For example, the former magnet needs the refrigeration system and the latter magnets usually use considerably large capacitor bank. Moreover, usually pulse magnets have the pulse with less than one m-sec and some of them are destructive so that they are not so convenient for engineering purposes.

The new generator proposed by the authors uses a relatively small scale electric source which is convenient for various engineering demands. The central idea is that the magnetic flux is compressed by the rotating metal discs which push the flux into the space surrounded by these discs. In other words, the discs act as a liner of the flux compression method. Our generator can be operated non-destructively at room temperatures and no large electric energy source is needed.

EDDY CURRENTS IN A CONDUCTIVE PLATE MOVING BETWEEN MAGNETIC POLES AND ITS EFFECT

We consider the conductive plate moving between magnetic poles in Fig.1. The steady-state flux passes through a conductive plate as a plate does not move. But when a conductive plate is moving at velocity V , the flux passing through a plate decreases in proportion to velocity. The plate is perfectly shielded from a magnetic flux at an infinite high speed.

The eddy current problem as shown in Fig.1 can be analyzed from Maxwell's equations (Eq.1),

As we assume that a conductive plate is very thin, the field problem in Fig.1 can be considered to be a two-dimensional one. The calculated results are

Manuscript received March 8, 1983.

Kazuo Bessho and Norio Miura are with Electrical Energy Conversion Laboratory, Faculty of Technology, Kanazawa University, 2-40-20 Kodatsuno, Kanazawa 920, Japan and Sotoshi Yamada is with the Department of Electrical Engineering, Faculty of Technology, Kanazawa University.

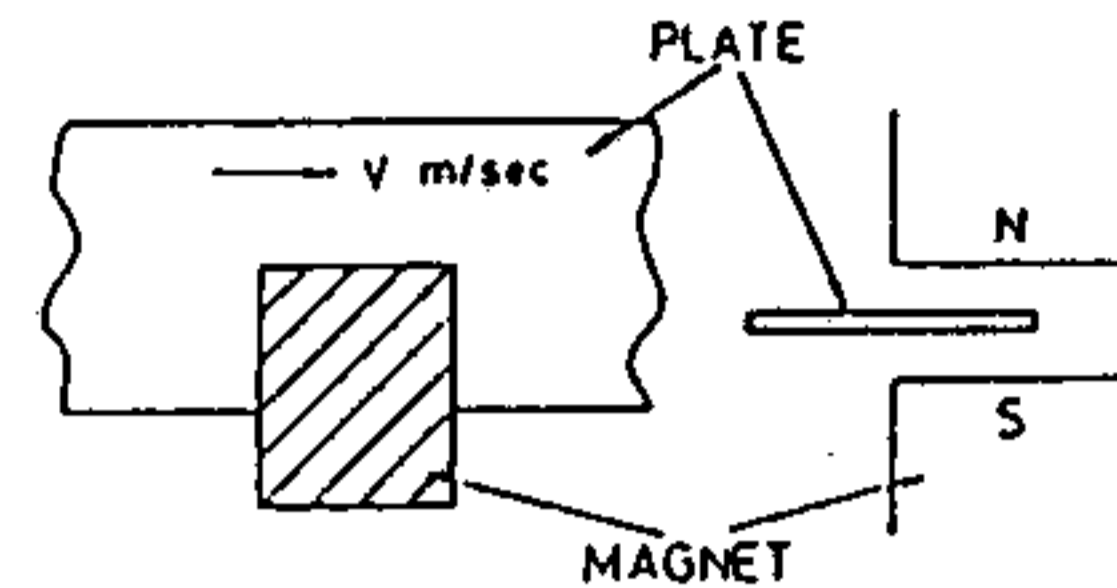

Fig.1 Conducting plate moving between magnetic poles

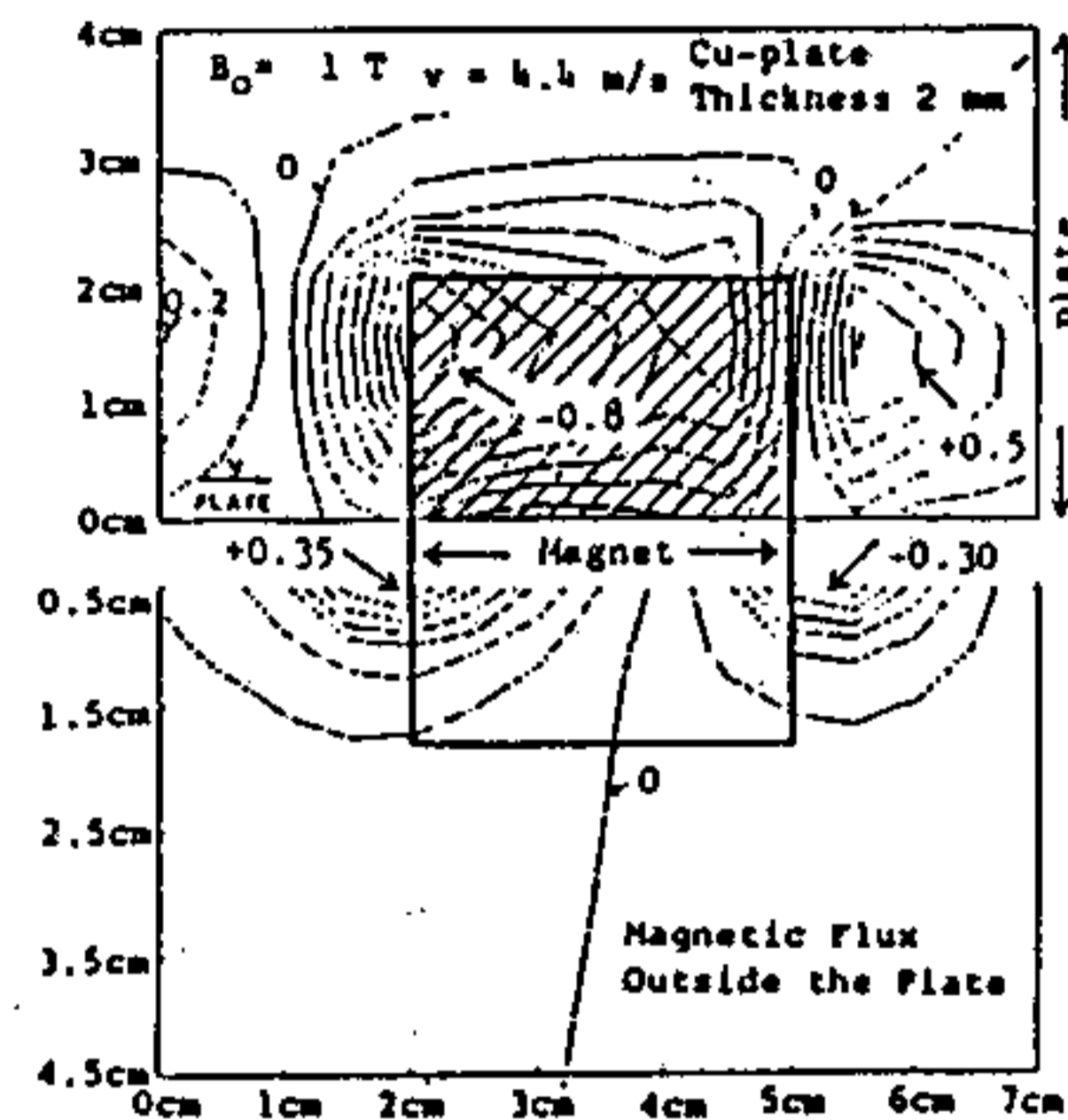

Fig.2 Flux density induced by eddy currents

$$\begin{aligned} \operatorname{div} J &= 0, \\ J &= \sigma [E_e + V \times (B_0 + B_e)], \\ E_e &= -\operatorname{grad} \phi, \\ \operatorname{rot} H_e &= J, \\ B_e &= \mu H_e, \end{aligned} \quad (1)$$

where, J : eddy current density,
 E_e : induced electromotive force,
 B_0 : applied flux density,
 B_e : induced flux density,
 V : velocity of plate,
 σ : conductivity,
 ϕ : scalar potential,
 μ : permeability.

illustrated in Fig.2[2]. The eddy currents in a plate are induced by an applied flux density ($B_0=1.0T$) and due to eddy currents the induced flux weakens the applied one. The flux density outside a plate increases because the induced flux is added to the applied one. The induced flux increases with the thickness of a conductive plate and the velocity of the plate. Behind the contour of a magnet, the induced flux rises in the same direction as the applied one but becomes weak at a high speed.

CONFIGURATION OF THE TEST EQUIPMENT

Figure 3 shows the outline of the test equipment with a conductive disc and an electromagnet. The applied flux is screened by the high speed rotating disc and the magnetic path is changed. The phenomena

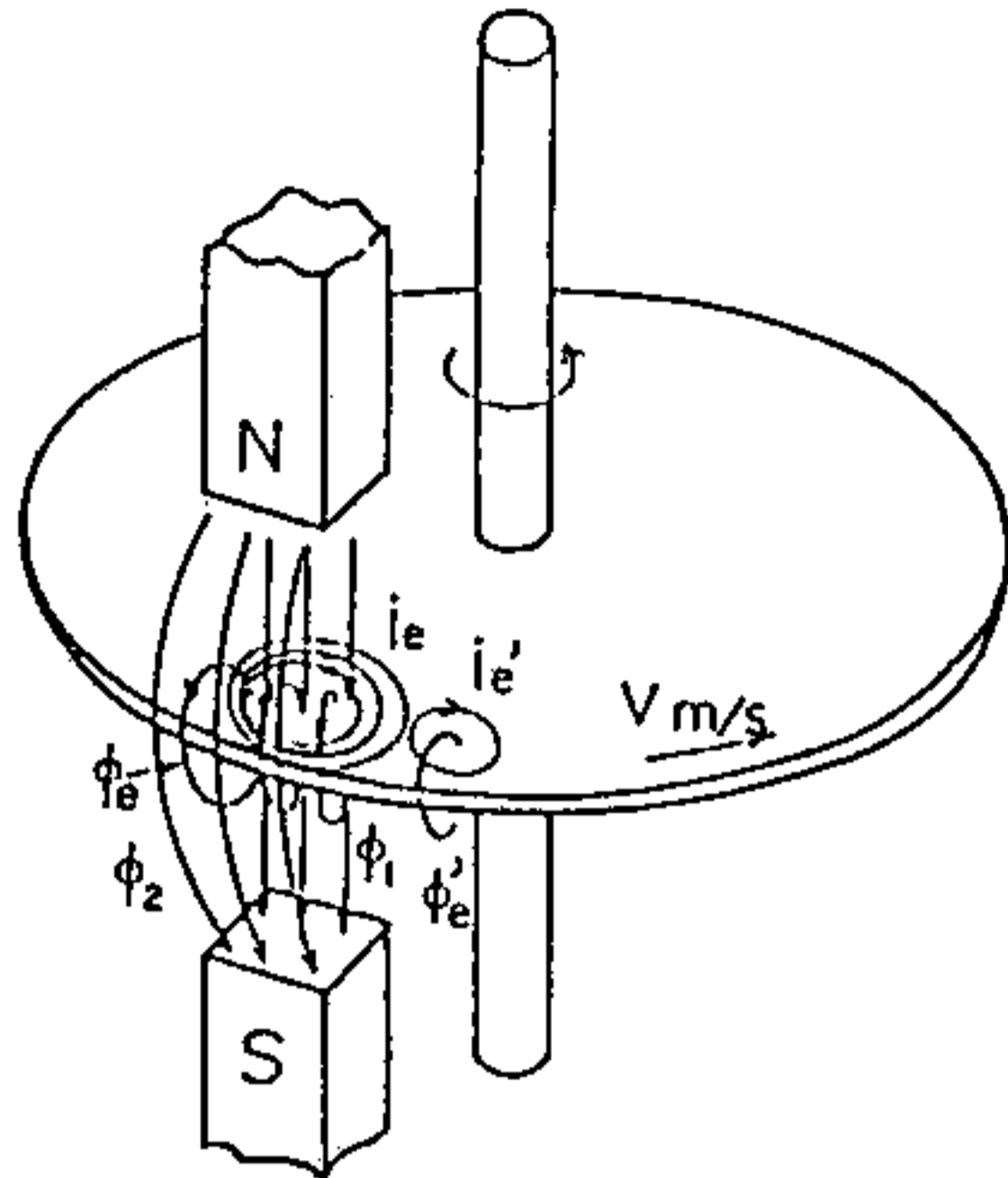

Fig.3 Screening effect by eddy currents

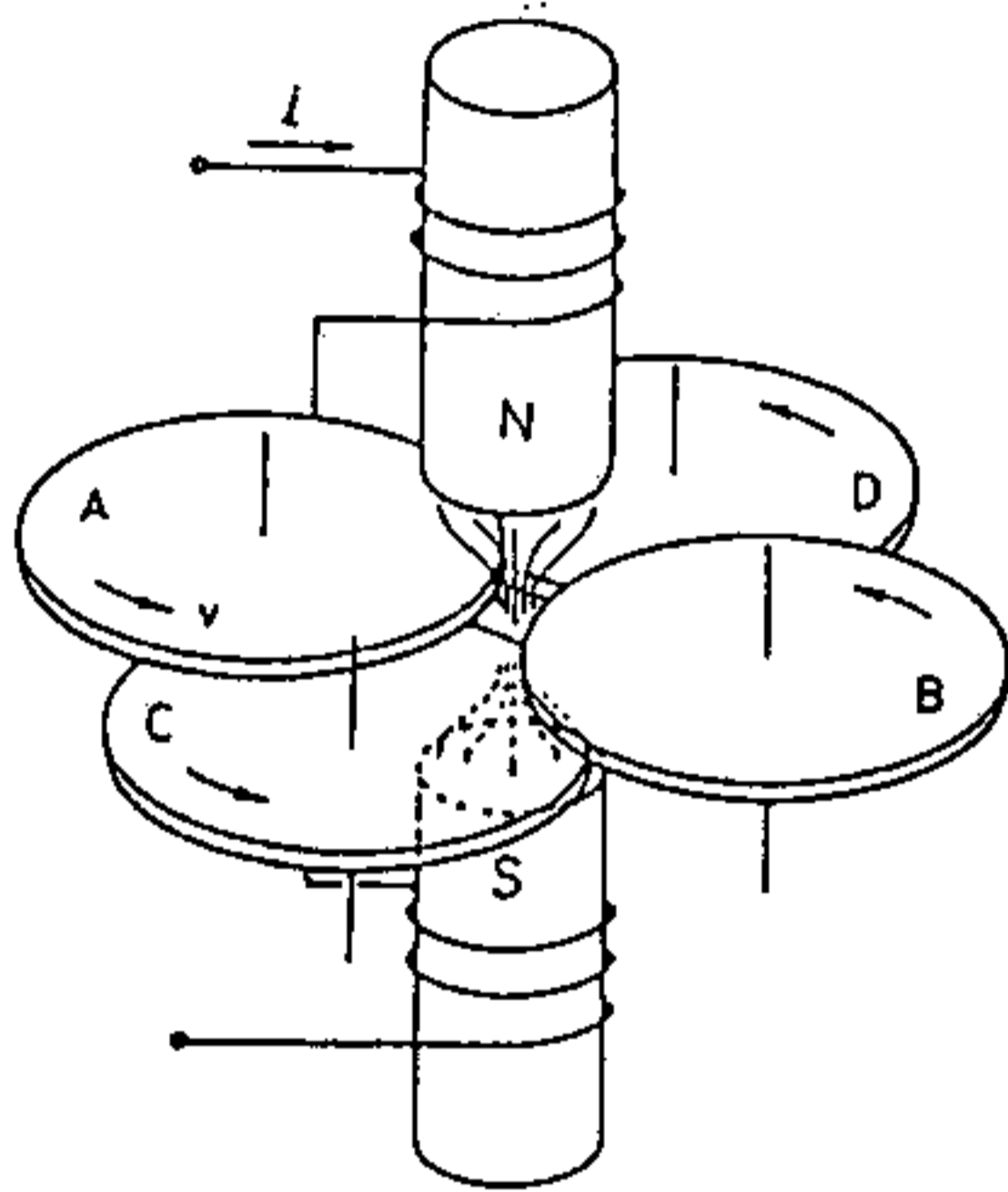

Fig.4 Principal configuration of the generator

mentioned in the last section can be confirmed by the test equipment.

The high magnetic field generator under consideration is based on the above theory. The generator has an air hole surrounded by four rotating discs in Fig.4. The flux applied by an electromagnet is concentrated in the air hole and high magnetic field can be generated.

It should be noticed that the eddy currents induced on the discs produce a considerable braking force. When the flux is compressed by the discs, the reacting force on the rotating discs acts as a braking force. Therefore, it is necessary to make large discs to keep enough moment of inertia.

Figure 5 shows the time process of concentrating a magnetic flux on the device. The rotating disc is driven by an induction motor. After the discs are disconnected from the motor, an exciting current i is supplied to an electromagnet at the time t_1 and the flux ϕ_1 is generated between magnetic poles. The flux ϕ_1 is concentrated by eddy currents induced in the disc and the high magnetic flux density B_2 is generated in the hole. The braking force F by eddy currents acts on the discs and the rotating speed of the discs decreases rapidly. The braking force indicates the maximum force F_m when the rotating speed becomes V_{min} at the time t_2 . The magnetic screening effect of conductive disc and the concentration of flux become weaker at the rotating speed under the speed V_{min} . The magnetic flux density in the hole decreases rapidly and becomes B_{1m} as the rotating of discs stops. The exciting current is cut down at the time t_4 and the process is finished at the time t_5 .

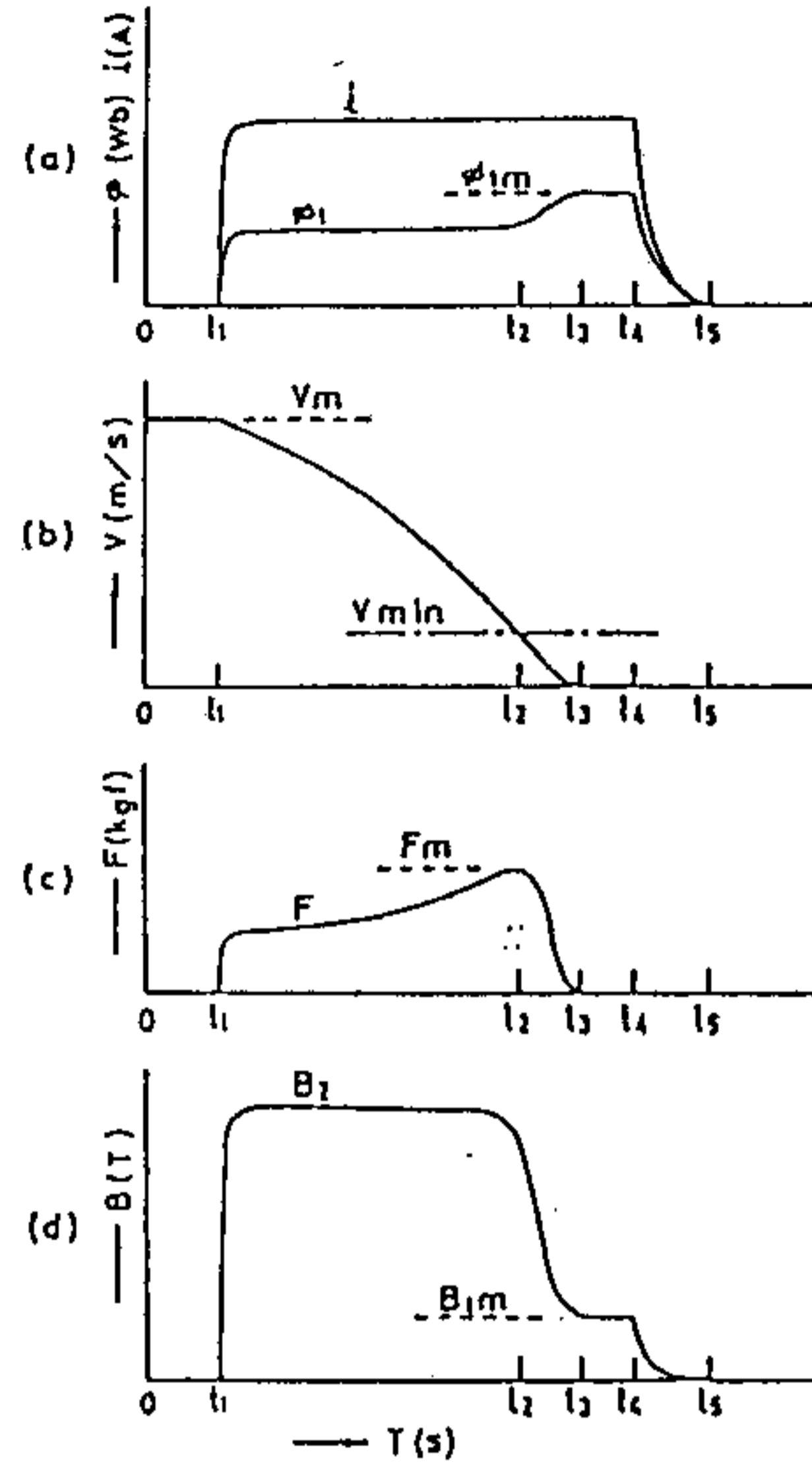

Fig.5 Process of concentrating a flux on the device
 (a) Exciting current and induced flux
 (b) Velocity on the circumference of discs
 (c) Braking force acting on discs
 (d) Magnetic flux density in the hole

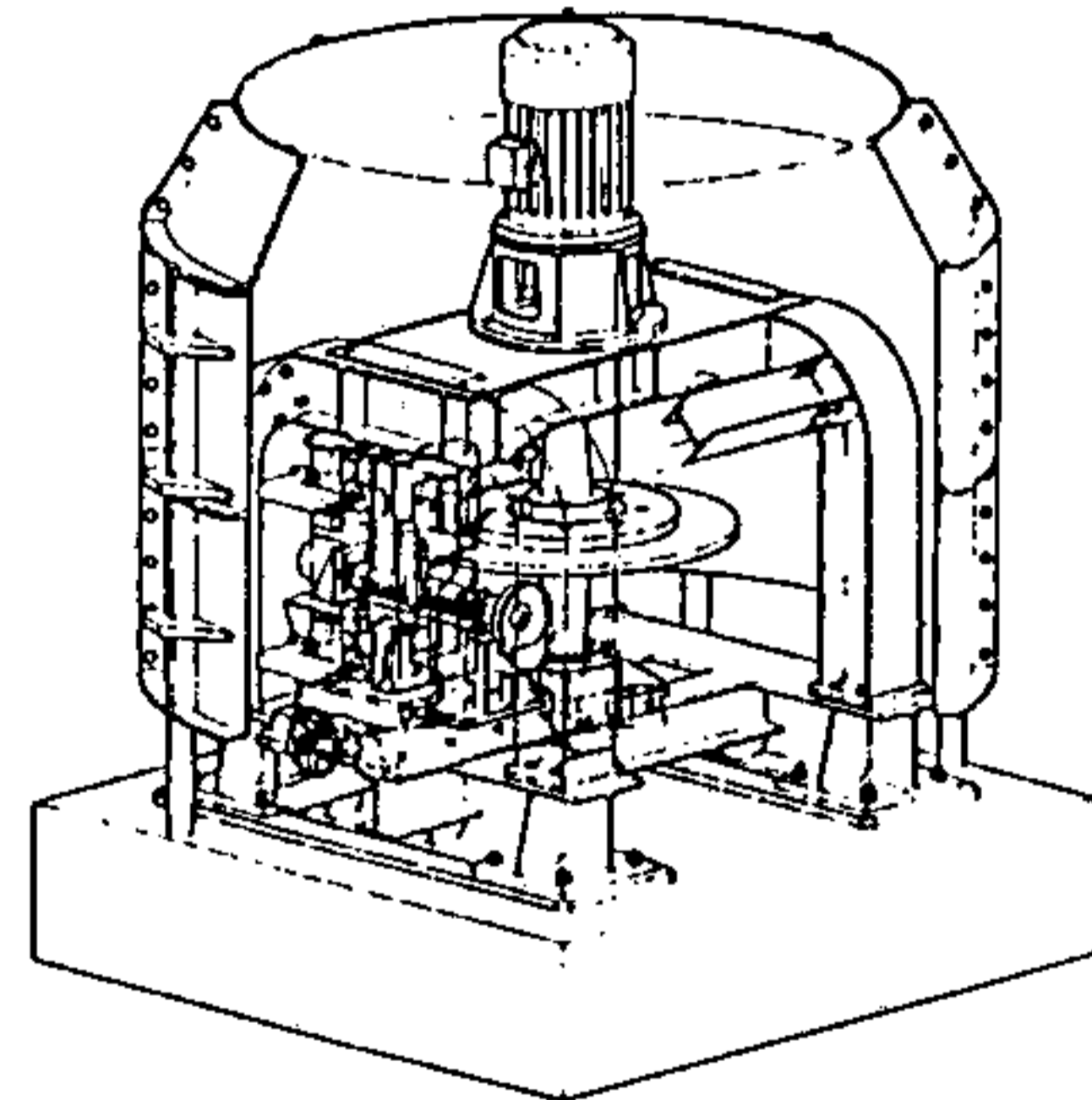

Fig.6 Experimental apparatus

Electromagnet

Cross section ; 5 x 5 cm , exciting turn number ; 659 x 2 turn, exciting current ; 100 A.

Disc

Material ; copper, diameter ; 70 cm, thickness ; 2 cm, mass ; 197 kg, inertia ; 5.9 kg m², max. rotating speed ; 3600 rpm.

As the magnetic screening effect and concentration of flux become weak between t_2 and t_3 , the magnetic reluctance and the leakage flux decreases respectively and the flux increases from ϕ_1 to ϕ_{1m} . ϕ_{1m} and B_{1m} are the same that are generated by an electromagnet without disc.

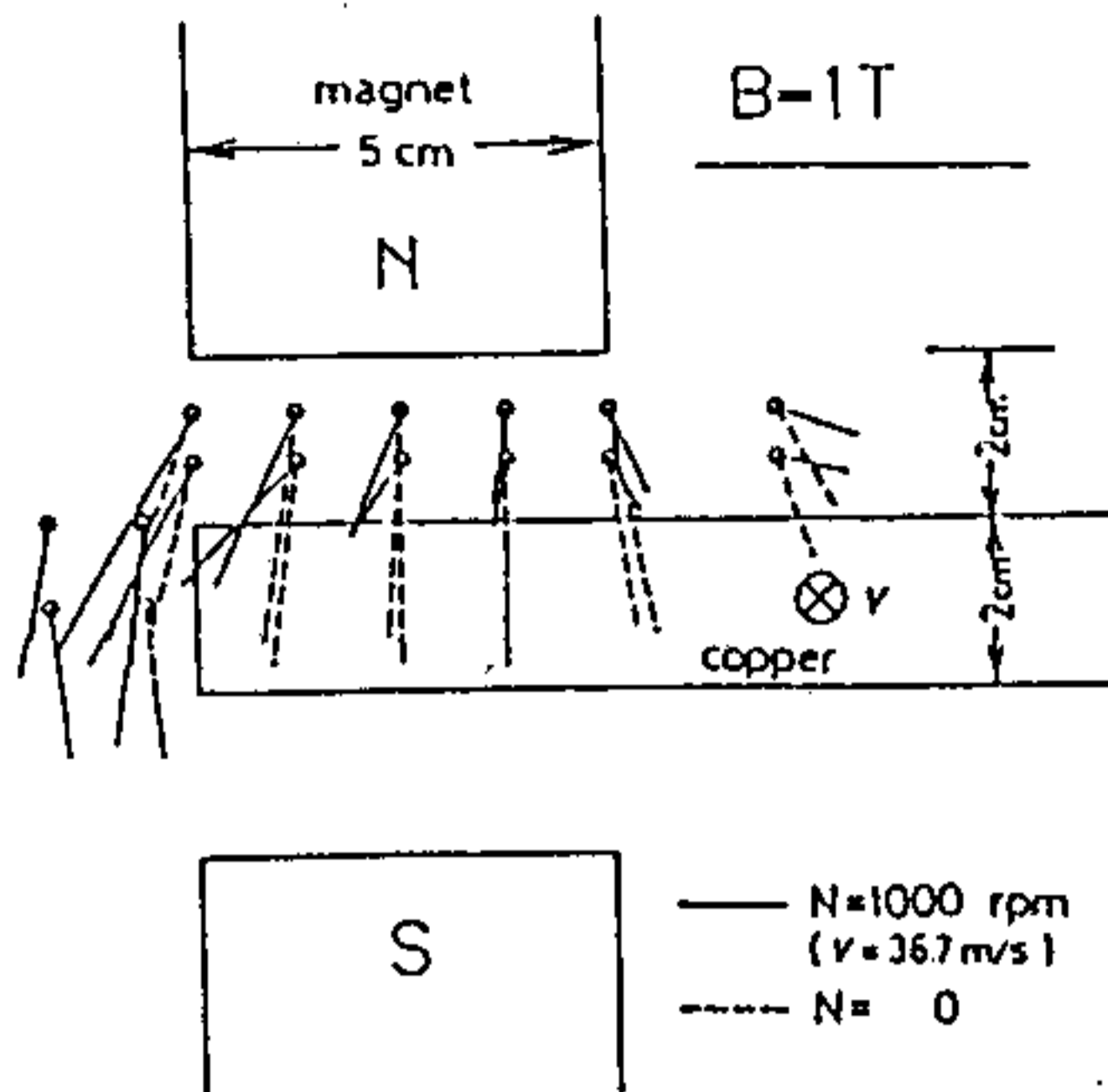

Fig. 7 Magnetic flux density (experiment)

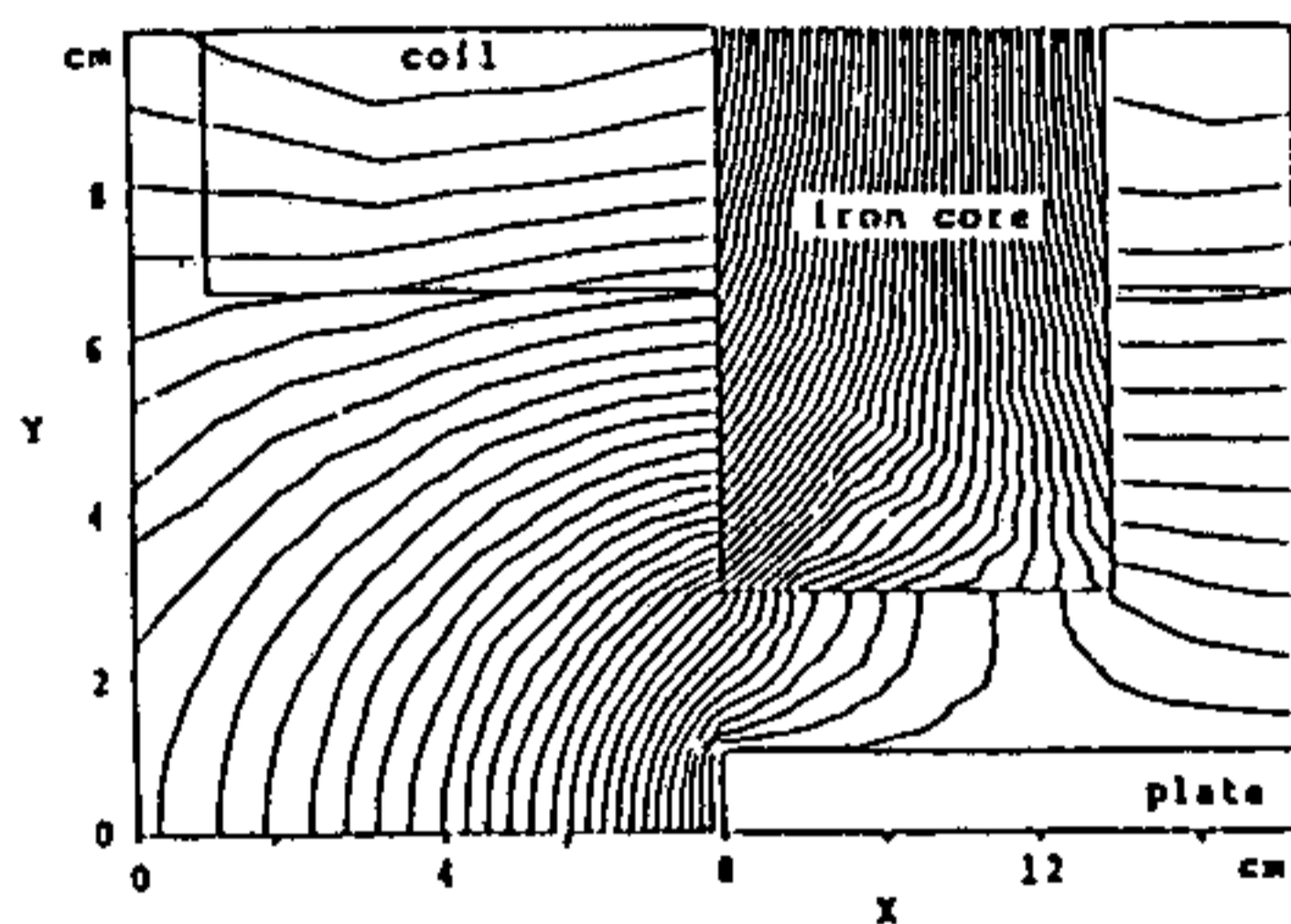

Fig. 8 Flux distribution (calculation)

EXPERIMENTAL AND CALCULATION

Figure 6 shows the experimental equipment with a rotating disc and an electromagnet. The magnetic screening effect and the path of a magnetic flux during disc rotation were investigated and the data for designing the advanced equipment could be obtained.

Figure 7 shows the magnetic flux densities (vector) on the plane perpendicular to the rotating direction. For comparison, vectors in two cases (rotating speed $N=1000$ rpm and 0 rpm) are illustrated by solid and dotted line. The computed flux distribution is shown in Fig. 8. In this calculation, we assume that the high speed rotating disc is equivalent to the perfect magnetic shield (a diamagnetic material) and the two-dimensional problem can be considered.

Figure 9 shows the flux distribution in the case when magnetic flux is concentrated into the slit between two rotating discs, as is done by superconductors. The more narrow slit results in the increase of the leakage flux and the flux density does not become higher in proportion to a/b . The increase of the flux density in the slit is concerned with not only a/b , but also other parameters, such as a gap length c , dimensions of exciting windings and discs, and magnetomotive force in particular. The concentration hole is built up by two slots crossing each other on the advanced equipment. The magnetic concentration ratio is defined as,

$$\alpha = \frac{B_2}{B_{1m}} = k \left(\frac{a}{b} \right)^2 \quad (2)$$

where k ($k \leq 1.0$) is leakage factor.

It is very important to design the optimum shape in order to minimize the leakage flux.

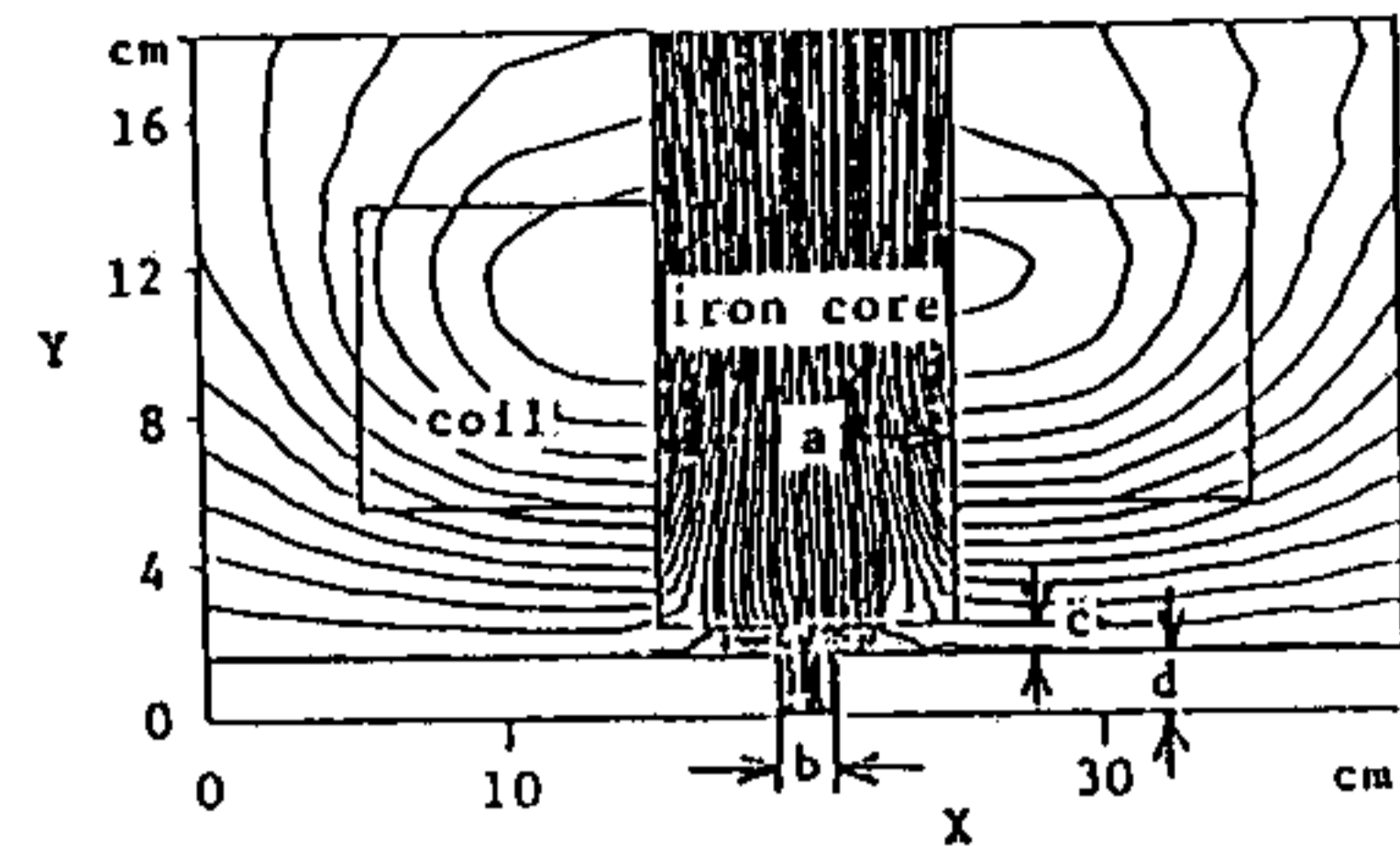
Fig. 9 Flux concentration in the slit (calculation)
 $a = 10$ cm, $b = 2$ cm, $c = 1$ cm, $d = 2$ cm

CONCLUSION

The results of the experiment are summarized as follows,

- (1) The magnetic screening and concentrating effects of a disc were observed at a velocity of a conductive disc (copper) higher than 9 m/s.
- (2) The braking force acting on the disc shows the maximum value at 9 m/s and decreases with increasing velocity.
- (3) The heating of a disc due to eddy currents loss is not so serious because the disc has a relatively large thermal capacity and is air-cooled.

As the flux distribution is asymmetric on the both sides of a disc, the magnetic force acts perpendicularly on the disc. Figures 8 and 9 suggest that the magnetic pressure in the direction of axis is not so strong and may not be so serious in the mechanical design of the equipment. The radial component of the magnetic force acting on the disc is the strongest and may cause the mechanical problem.

It is confirmed in the results that the maximum concentration ratio α expressed in Eq. 2 may be approximately $15 - 20$. We consider that it may be possible to generate a magnetic field up to $20 - 30$ T on the advanced equipment based on the new idea.

The principle can be applied to an alternating high field generator with 50 or 60 Hz by the use of an alternate electromagnet. This is one of the special extension of the new principle.

ACKNOWLEDGEMENT

The authors wish to thank Mr. Chyo Chyama, the Ministry of Education and Mr. Kiyoshi Nishimura, the head of Accountants Department, Kanazawa University, for giving an opportunity to develop the equipment. We also want to acknowledge Prof. Muneyuki Date, High Magnetic Field Laboratory, Osaka University for suggestions.

REFERENCES

- (1) K. Bessho, S. Yamada; "High speed rotating disc type device for magnetic field concentration", *JIEE Annual Conf. on Magnetics*, MAG-82-52, '82.
- (2) T. Morisue; "Analysis of three-dimensional eddy currents problem by magnetic vector potential method", *JIEE Annual Conf. on Rotating Machines*, RM-82-42, '82.
- (3) K. Bessho, S. Yamada; "High speed rotating disc type generator for high magnetic field", *Proc. of the International Symposium on High Field Magnetism*, p323-326, '82.
- (4) K. Bessho; "High magnetic field generator with high speed rotating disc", *Japanese Scientific Monthly*, Vol. 35, No. 9, Dec., '82.